

中華民國第 60 屆中小學科學展覽會

作品說明書

國中組 地球科學科

佳作

030506

墩的好—柔性葉片環圈預防橋墩周圍侵蝕之相關探討

學校名稱：新北市立文山國民中學

作者： 國二 石昀弘 國二 林昱嘉 國二 葉弘凱	指導老師： 周瑞玲 賴瑋倩
-----------------------------------------------	-----------------------------

關鍵詞：柔性葉片環圈、橋墩侵蝕

摘要

本研究主要目的為探討柔性葉片環圈是否能有效減緩橋墩周圍侵蝕，並在何種條件下效果最佳；本研究運用自製的水道模型，等比例縮小碧潭大橋及柔性葉片保護工，設置不同的葉片形狀、不同環圈排列方式及三角形排列時不同的頂角，會對流速、橋墩周圍侵蝕及周邊地形造成何種影響，最後拿實驗中最好的比例來和消波塊比較效果。

由研究結果可知，柔性葉片環圈能有效減緩橋墩周圍侵蝕，且當選用三角形的葉片時，其效果較佳，而安置環圈時，將其排成頂角面對水流的三角形，成果較佳，且其成效也較消波塊好，推測可能可以產生分流的效果；另三角形排列的夾角，應與橋墩之間存在特定比例關係，而非越大越好或越小越好，以結果來看，60度夾角最佳。

壹、研究動機

我們在上自然課的時候，課本提到台灣常用消波塊來保護橋墩或海岸不被侵蝕，然而其製造時要消耗大量水泥及砂石，會破壞水土保持及地形景觀，且當波浪太大，消波塊可能會無法承受不了波浪的撞擊而破碎，導致整塊被捲起並衝撞堤岸，若擺放不當，也可能增強附近渦流，使消波塊更快沉降（林宗儀，2019）。

於是我們思考有哪些方法能取代消波塊，偶然發現了柔性葉片環圈工法，它只需要廢輪胎和一些鋁片，取得容易也能用輪胎吸震，且不會破壞原有橋墩的設置，最重要的是容易更換，所以就選擇了柔性葉片環圈作為我們的實驗對象，探討安置後對橋墩侵蝕的影響，並和消波塊比較。

貳、研究目的

- 一、設計模擬實驗渠道。
- 二、探討不同形狀的柔性葉片減少河道侵蝕的功效。
 - （一）三角形的柔性葉片環圈。
 - （二）鐮刀形的柔性葉片環圈。
 - （三）圓形的柔性葉片環圈。
- 三、探討不同排列的柔性葉片環圈減少河道侵蝕的功效。
 - （一）三角形（頂角朝向水流來向）。

(二) 三角形 (對邊朝向水流來向)。

(三) 橫列 (與河川流向垂直)。

四、探討三角形擺法在不同頂角下的柔性葉片環圈減少河道侵蝕的功效。

(一) 鈍角三角形 (頂角為 135°)。

(二) 直角三角形 (頂角為 90°)。

(三) 正三角形 (頂角為 60°)。

(四) 銳角三角形 (頂角為 45°)。

五、探討柔性葉片環圈和消波塊減少河道侵蝕的功效。

(一) 排列為三角形 (頂角朝向水流來向) 頂角 60° 的柔性葉片環圈。

(二) 排列為三角形 (頂角朝向水流來向) 頂角 60° 消波塊。



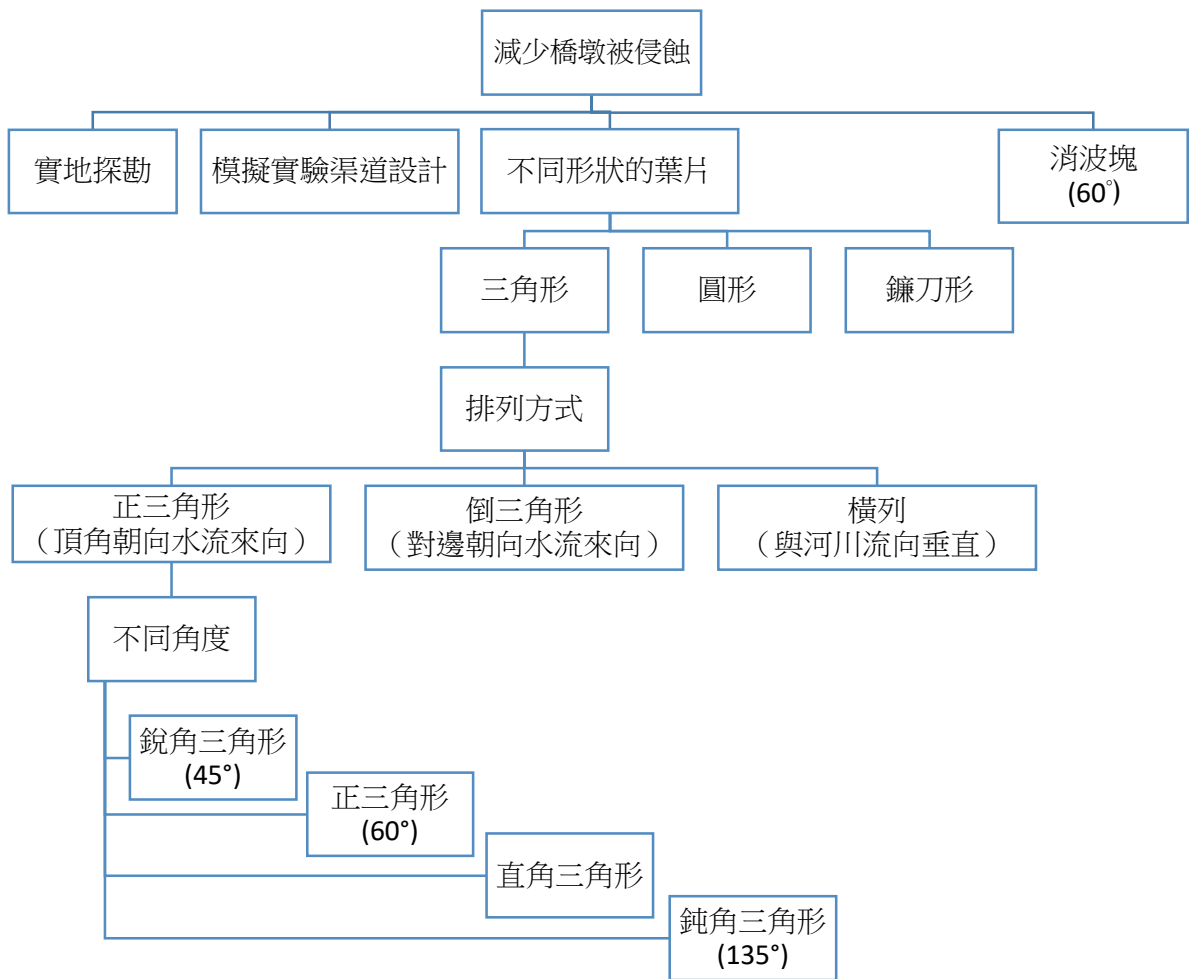

參、研究架構



肆、設備及器材





一、 器材

水桶	麻布袋	水盆
熱熔膠槍	鏟子	大滴管
手套	鋁罐	樂高輪胎 (外徑：21mm、 內徑：12mm) (型號：87697)
		
pvc 水管 (外徑：76mm、 內徑：74mm) (尺寸：21/2")	水管 (外徑：250mm、 內徑：200mm) (尺寸：6")	水箱 (90 公升)
		
多用途光電控制計時計數器	紅外光電傳感器	抽水馬達 (Narex-A PTC-100)
		

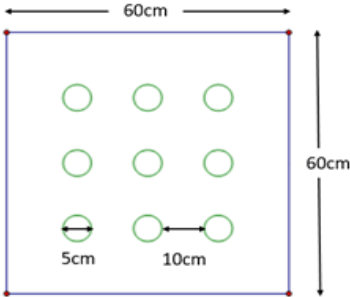
雷射測距儀 (BOSCH 30m 雷射測距儀 GLM 30)	河砂	鋸子
		
水泥消波塊(6cm*6cm*6cm)		
		

二、自製器材

器材	照片	製作過程
水道		<p>1. 尺寸</p> <p>(1) 整體尺寸</p> <p>(2) 出水端尺寸</p> 

		<p>2. 整體配置</p> <p>(1) 前段：為導流段，放置導流板使水流穩定流出。</p> <p>(2) 中段：為試驗端，佈置泥砂，下方用珍珠板墊高，使水能完全流出。</p> <p>(3) 後段：為出水端，水流自出水孔流出，進入蓄水箱後，再固定使用兩個抽水馬達作為固定流速，把水抽回導流段，達成循環的水流系統。</p>
珍珠板架		<p>1. 做法：將珍珠板搭配水道用刀片切割成適當大小，並黏貼起來，在上方黏上木板以防珍珠板架彎曲，然後將 60cm 的珍珠板架每隔 6cm 分隔開，切割 10 個孔洞。</p> <p>2. 用處：能在使用雷射測距儀時，將其放上孔洞上，隨之移動，固定每次觀察的位置。</p>
環圈固定架		<p>1. 做法：將竹筴切割成適當長度後，用膠帶貼在完整的竹筴上，呈十字型。</p> <p>2. 用處：固定環圈，以防沖水實驗時環圈被水沖走。</p>
橋墩		<p>1. 尺寸及材質：橋墩以 pvc 水管（外徑：76mm、內徑：74mm）製成，高度為 310mm。</p> <p>2. 做法：用鋸子切割出適當長度的水管，並在上方黏貼護備後的尺寸條。</p>
導流板	 	<p>1. 做法：把吸管剪半，再數個綁成一網，上方以砝碼壓住。避免被水流沖走。</p> <p>2. 作用：讓水流的方向和流速一致。</p>

柔性
葉片
環圈



左為鐮刀形葉片

右為三角形葉片



為圓形葉片

1. 尺寸及材質：輪胎採用樂高橡膠輪胎（外徑：21mm、內徑：12mm），葉片則長為 15mm，寬為 10mm，黏貼處 5mm），而樂高橡膠輪胎和我們設計的橋墩比例，與真實的碧潭大橋與輪胎一致。

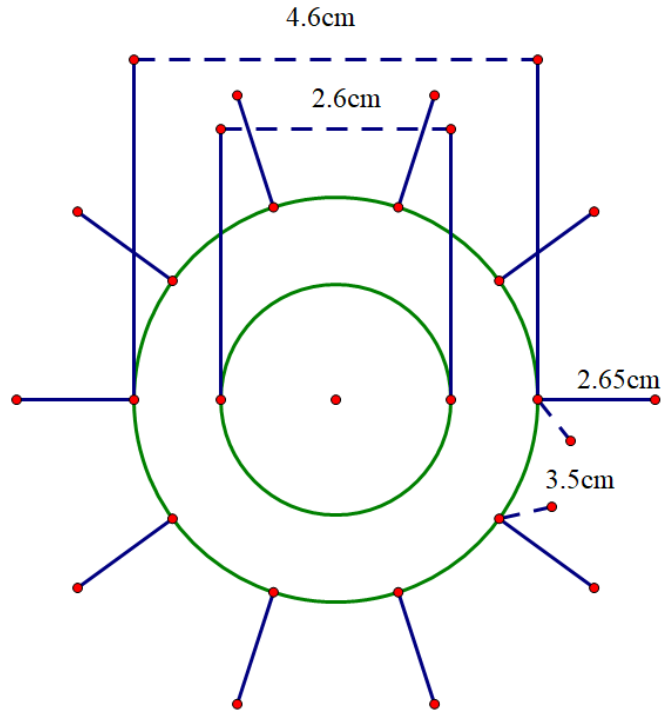

圖一：鋁製葉片固定於樂高輪胎上之尺寸

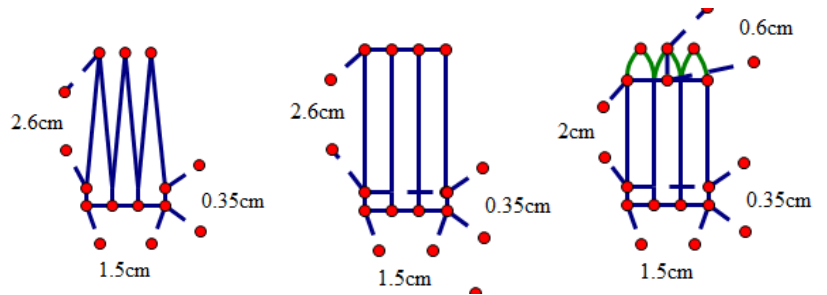

圖二：三角形葉片 圖三：鐮刀形葉片 圖四：圓形葉片

2. 做法：使用刀片切割鋁罐，並用熱熔膠黏貼在輪胎上，皆黏十片葉片。

三、使用軟體

1. Microsoft Office Excel 2016。
2. GSP 5.0 軟體。
3. Image J。

伍、文獻探討

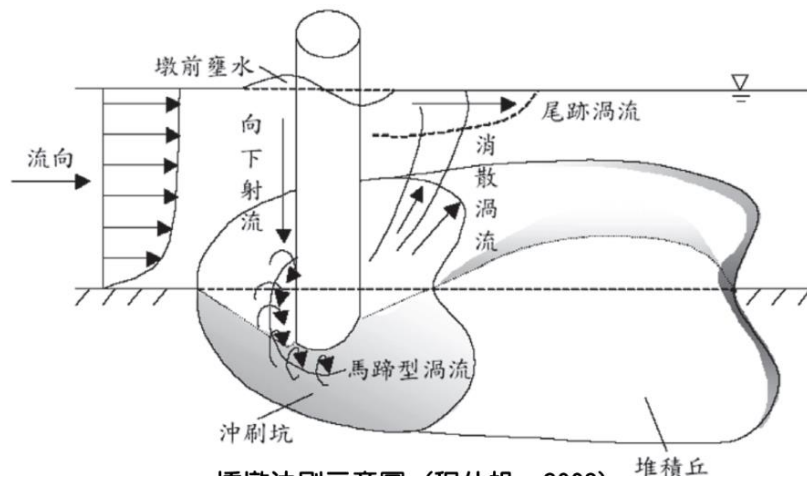

圖五：橋墩冲刷示意圖（程仕帆, 2003）

水流在冲到橋墩時，會因橋墩的阻擋而停止，但又因為後方的水還在持續流動而把前方的水往各方推移，而向上的水流，會上方產生壅水，向下方產生向下射流，向下射流在撞到河床時，並在橋墩和河床之間產生馬蹄形渦流，此渦流對河床具有淘刷能力，會使橋墩前形成冲刷坑，且會隨著時間加深、擴大，造成橋墩基樁裸露，導致影響橋墩的穩定性，甚至導致倒塌。

我們測量流速是因為流速會影響到向下射流的形成，所以測量流速來計算該葉片環圈的功效，拍攝橋墩四方的圖片是因為向下射流會導致馬蹄形渦流的形成，則如果向下射流減緩，馬蹄形渦流也會變小，因此用來測量該葉片環圈的功效，而測量地形是為了測量該葉片環圈對減少整體渦流的形成，和對地形的保護的功效。

陸、研究過程與方法

一、實驗配置

(一) 探勘

1. 新店溪碧潭大橋，並向新北市第十河川局詢問橋墩尺吋。
2. 新店溪碧潭大橋下方的消波塊。

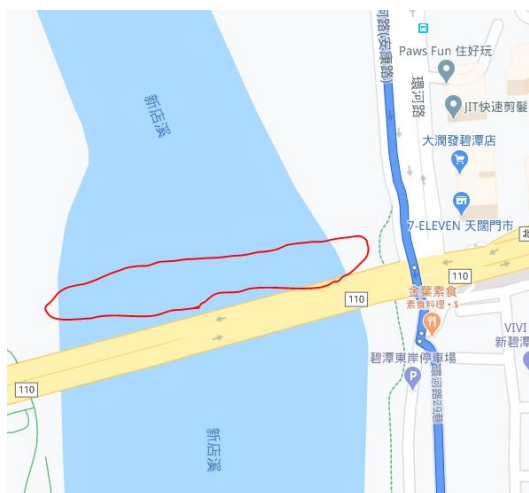

圖六：探勘新店溪碧潭大橋

圖七：探勘新店溪碧潭大橋下方消波塊

- (二) 泥沙來源：本實驗設計參照新店溪碧潭流域段，為確保粒徑大小與碧潭一致，所以本實驗使用之土壤底質來自於碧潭河岸。



圖八：探勘範圍



圖九：挖砂過程

(三) 實驗操作程序

1. 實驗前

- (1) 裝置實驗器材於相對位置，把保護工置於橋墩前方三倍處，根據王傳益、呂其倫、張詠善及鄭人豪(2012)所述，若僅置於橋墩前方兩倍處，則橋墩及保護工會被視為一個連體，因受水流的作用面較大，形成劇烈紊動，所以會造成較大沖刷深度，但若置於橋墩前方九倍處，因由於距離較遠，使保護工所削弱之水

流效果，無法擴及至墩前，加上考量本身水道模型尺吋後，決定把保護工置於橋墩前方三倍處。

- (2) 測試水流循環系統流動情形。(圖十)
- (3) 將橋墩模型置於水道固定位置。(圖十一)
- (4) 把柔性葉片環圈柱群依設定變因，設置於預定位置。
- (5) 把位於試驗端的泥砂均勻地鋪平並夯實。(圖十二)
- (6) 開啟位於蓄水箱的兩台馬達，並搭配水管引流至導流端，同時開始計時。



圖十：測試流動情形



圖十一：固定橋墩



圖十二：泥砂鋪平及夯實

2. 實驗中

- (1) 使用乒乓球和光電計時器來測量柔性葉片環圈柱群前後的流速，使乒乓球分別流過第一台及第二台紅外光電傳感器，記錄經過兩者間的所需時間，有效位數設置為小數點下兩位數，若該組標的物偏移，則不計此次數據；各自重複記錄十組後，計算其平均及標準差。(圖十八)
- (2) 待沖刷時間達 15 分鐘結束後，關閉抽水馬達。

3. 實驗後

- (1) 使試驗段的水洩掉，並搭配大滴管把剩餘水分抽乾。
- (2) 拍攝橋墩四邊的尺吋，並記錄下來。(圖十三至圖十六，及圖二十)



圖十三：橋墩前

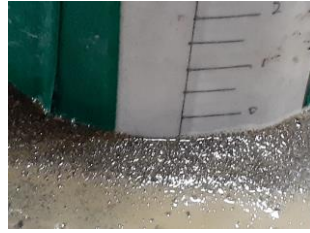

圖十四：橋墩後



圖十五：橋墩左

圖十六：橋墩右

(3) 用雷射測距儀搭配珍珠板架量測河床的剖面高度，並拍攝橋墩模型四邊土堆下降或上升的尺度，把數據照最小值(0.499m)至最大值(0.588m)依序切成 15 等份，並以顏色標示其高度，越近深咖啡色的地形愈高，越近深綠色的地形愈低。(圖十七及圖二十)



圖十七：地形示意圖



圖十八：感測器位置 圖十九：雷射測距儀測量過程 圖二十：橋墩侵蝕高度測量

4. 因應不同操作變因而改變不同配置，並重複以上步驟。

二、對照組試驗

示意圖	說明
	<p>僅放置橋墩，前後無任何保護工。</p>

三、探討不同形狀的柔性葉片減少河道侵蝕的功效

葉片形狀	示意圖	說明
<p>三角形</p>		<p>將 12 個葉片為三角形的柔性葉片環圈以排列成正三角形（頂角朝向水流來向）的形式，擺在橋墩前方的三倍直徑處。</p>
<p>鐮刀型</p>		<p>將 12 個葉片為鐮刀形的柔性葉片環圈以排列成正三角形（頂角朝向水流來向）的形式，擺在橋墩前方的三倍直徑處。</p>

圓形		將 12 個葉片為圓形的柔性葉片環圈以排列成正三角形（頂角朝向水流來向）的形式，擺在橋墩前方的三倍直徑處。
----	------------------------------------------------------------------------------------	-------------------------------------------------------

四、探討不同排列方式的柔性葉片環圈減少河道侵蝕的功效

排列方式	示意圖	說明
三角形（頂角朝向水流來向）		將 12 個葉片為三角形的柔性葉片環圈柱以正三角形的形式（頂角朝向水流來向），擺在橋墩前方的三倍直徑處。
三角形（對邊朝向水流來向）		將 12 個葉片為三角形的柔性葉片環圈柱以倒三角形的形式（對邊朝向水流來向），擺在橋墩前方的三倍直徑處。
橫列（與河川流向垂直）		將 12 個葉片為三角形的柔性葉片環圈柱以橫列的形式（與河川流向垂直），擺在橋墩前方的三倍直徑處。

五、探討不同頂角的三角形柔性葉片環圈減少河道侵蝕的功效

排列方式	示意圖	說明
45 度		<p>將 12 個葉片為三角形的柔性葉片環圈柱以三角形（頂角為 45 度），擺在橋墩前方的三倍直徑處。</p>
90 度		<p>將 12 個葉片為三角形的柔性葉片環圈柱以三角形（頂角為 90 度），擺在橋墩前方的三倍直徑處。</p>
135 度		<p>將 12 個葉片為三角形的柔性葉片環圈柱以三角形（頂角為 135 度），擺在橋墩前方的三倍直徑處。</p>

六、探討消波塊減少河道侵蝕的功效

頂角 60 度		<p>將 12 個消波塊以三角形（頂角為 60 度），擺在橋墩前方的三倍直徑處。</p>
---------	--------------------------------------------------------------------------------------	----------------------------------------------

(四) 討論

於這組實驗中，先設定三種不同形狀的葉片-三角形、鐮刀形及圓形做為討論對象，且先皆以正三角形（頂角朝向與河川流向為 180 度夾角）方式排列，而從數據中可看到，當葉片是三角形時能使流經的速度下降，也是最能使橋墩前方不再產生侵蝕，甚至能有堆積出現，而在地形圖中，可看到不論在橋墩前方或後方，皆能出現堆積，證明能有效抵擋水流沖蝕，然觀察圓形葉片的流速時，可看到其減緩流速的能力是最差的，且無法在橋墩前方形成堆積，而在橋墩後方也較不能形成堆積。

我們推估可能是因三角形葉片相較圓形及鐮刀葉片，較能用尖刺使水流流速被減慢，讓水流雖然受到擾亂，使得一道快而範圍廣的水流，變為多道流速較慢且方向不同甚至會相互干擾摩擦的水流，更導致當水流流經橋墩後方時，因能量不足，而無法帶走泥沙，進而使泥沙在後方沉澱下來，而圓形葉片可能因其形狀，使水流被分散的力道較小，導致效果較差。

二、探討不同排列方式的柔性葉片環圈減少河道侵蝕的功效

(一) 地形圖-白色圓形圖示為橋墩，藍色圖示為保護工。

對照組																																																																																																																																																																																																																																																																																								
<table border="1"> <tr><td>0.576</td><td>0.575</td><td>0.57</td><td>0.565</td><td>0.566</td><td>0.564</td><td>0.56</td><td>0.571</td><td>0.573</td><td>0.569</td></tr> <tr><td>0.578</td><td>0.577</td><td>0.568</td><td>0.557</td><td>0.539</td><td>0.523</td><td>0.566</td><td>0.578</td><td>0.58</td><td>0.576</td></tr> <tr><td>0.572</td><td>0.572</td><td>0.564</td><td>0.559</td><td>0.558</td><td>0.56</td><td>0.56</td><td>0.575</td><td>0.575</td><td>0.575</td></tr> <tr><td>0.57</td><td>0.566</td><td>0.559</td><td>0.56</td><td>0.562</td><td>0.566</td><td>0.569</td><td>0.572</td><td>0.574</td><td></td></tr> <tr><td>0.562</td><td>0.561</td><td>0.558</td><td>0.55</td><td>0.563</td><td>0.565</td><td>0.57</td><td>0.572</td><td>0.572</td><td></td></tr> <tr><td>0.565</td><td>0.558</td><td>0.554</td><td>0.559</td><td>0.562</td><td>0.563</td><td>0.565</td><td>0.566</td><td>0.574</td><td>0.576</td></tr> <tr><td>0.562</td><td>0.559</td><td>0.56</td><td>0.554</td><td>0.554</td><td>0.558</td><td>0.566</td><td>0.567</td><td>0.57</td><td>0.574</td></tr> <tr><td>0.559</td><td>0.554</td><td>0.551</td><td>0.553</td><td>0.558</td><td>0.56</td><td>0.554</td><td>0.56</td><td>0.564</td><td>0.566</td></tr> <tr><td>0.557</td><td>0.553</td><td>0.55</td><td>0.551</td><td>0.553</td><td>0.557</td><td>0.555</td><td>0.56</td><td>0.564</td><td>0.568</td></tr> </table>																0.576	0.575	0.57	0.565	0.566	0.564	0.56	0.571	0.573	0.569	0.578	0.577	0.568	0.557	0.539	0.523	0.566	0.578	0.58	0.576	0.572	0.572	0.564	0.559	0.558	0.56	0.56	0.575	0.575	0.575	0.57	0.566	0.559	0.56	0.562	0.566	0.569	0.572	0.574		0.562	0.561	0.558	0.55	0.563	0.565	0.57	0.572	0.572		0.565	0.558	0.554	0.559	0.562	0.563	0.565	0.566	0.574	0.576	0.562	0.559	0.56	0.554	0.554	0.558	0.566	0.567	0.57	0.574	0.559	0.554	0.551	0.553	0.558	0.56	0.554	0.56	0.564	0.566	0.557	0.553	0.55	0.551	0.553	0.557	0.555	0.56	0.564	0.568																																																																																																																																																																															
0.576	0.575	0.57	0.565	0.566	0.564	0.56	0.571	0.573	0.569																																																																																																																																																																																																																																																																															
0.578	0.577	0.568	0.557	0.539	0.523	0.566	0.578	0.58	0.576																																																																																																																																																																																																																																																																															
0.572	0.572	0.564	0.559	0.558	0.56	0.56	0.575	0.575	0.575																																																																																																																																																																																																																																																																															
0.57	0.566	0.559	0.56	0.562	0.566	0.569	0.572	0.574																																																																																																																																																																																																																																																																																
0.562	0.561	0.558	0.55	0.563	0.565	0.57	0.572	0.572																																																																																																																																																																																																																																																																																
0.565	0.558	0.554	0.559	0.562	0.563	0.565	0.566	0.574	0.576																																																																																																																																																																																																																																																																															
0.562	0.559	0.56	0.554	0.554	0.558	0.566	0.567	0.57	0.574																																																																																																																																																																																																																																																																															
0.559	0.554	0.551	0.553	0.558	0.56	0.554	0.56	0.564	0.566																																																																																																																																																																																																																																																																															
0.557	0.553	0.55	0.551	0.553	0.557	0.555	0.56	0.564	0.568																																																																																																																																																																																																																																																																															
橫列（與河川流向垂直）	倒三角形（頂角朝向與河川流向一致）					正三角形（頂角朝向與河川流向為 180 度夾角）																																																																																																																																																																																																																																																																																		
<table border="1"> <tr><td>0.583</td><td>0.575</td><td>0.576</td><td>0.560</td><td>0.551</td><td>0.551</td><td>0.571</td><td>0.577</td><td>0.569</td><td>0.569</td></tr> <tr><td>0.579</td><td>0.571</td><td>0.560</td><td>0.560</td><td>0.559</td><td>0.567</td><td>0.573</td><td>0.580</td><td>0.572</td><td>0.562</td></tr> <tr><td>0.575</td><td>0.5</td><td>0.573</td><td>0.570</td><td>0.567</td><td>0.572</td><td>0.571</td><td>0.572</td><td>0.569</td><td>0.563</td></tr> <tr><td>0.563</td><td>0.5</td><td>0.564</td><td>0.568</td><td>0.573</td><td>0.569</td><td>0.570</td><td>0.563</td><td>0.561</td><td></td></tr> <tr><td>0.560</td><td>0.5</td><td>0.560</td><td>0.568</td><td>0.571</td><td>0.566</td><td>0.563</td><td>0.561</td><td>0.550</td><td></td></tr> <tr><td>0.562</td><td>0.5</td><td>0.562</td><td>0.567</td><td>0.568</td><td>0.567</td><td>0.564</td><td>0.562</td><td>0.555</td><td>0.550</td></tr> <tr><td>0.559</td><td>0.559</td><td>0.565</td><td>0.563</td><td>0.554</td><td>0.538</td><td>0.553</td><td>0.553</td><td>0.552</td><td>0.550</td></tr> <tr><td>0.545</td><td>0.556</td><td>0.559</td><td>0.560</td><td>0.558</td><td>0.557</td><td>0.560</td><td>0.556</td><td>0.551</td><td>0.544</td></tr> <tr><td>0.544</td><td>0.550</td><td>0.553</td><td>0.558</td><td>0.559</td><td>0.557</td><td>0.557</td><td>0.559</td><td>0.553</td><td>0.548</td></tr> </table>	0.583	0.575	0.576	0.560	0.551	0.551	0.571	0.577	0.569	0.569	0.579	0.571	0.560	0.560	0.559	0.567	0.573	0.580	0.572	0.562	0.575	0.5	0.573	0.570	0.567	0.572	0.571	0.572	0.569	0.563	0.563	0.5	0.564	0.568	0.573	0.569	0.570	0.563	0.561		0.560	0.5	0.560	0.568	0.571	0.566	0.563	0.561	0.550		0.562	0.5	0.562	0.567	0.568	0.567	0.564	0.562	0.555	0.550	0.559	0.559	0.565	0.563	0.554	0.538	0.553	0.553	0.552	0.550	0.545	0.556	0.559	0.560	0.558	0.557	0.560	0.556	0.551	0.544	0.544	0.550	0.553	0.558	0.559	0.557	0.557	0.559	0.553	0.548	<table border="1"> <tr><td>0.582</td><td>0.580</td><td>0.572</td><td>0.571</td><td>0.568</td><td>0.570</td><td>0.572</td><td>0.573</td><td>0.563</td><td>0.579</td></tr> <tr><td>0.566</td><td>0.561</td><td>0.561</td><td>0.565</td><td>0.564</td><td>0.565</td><td>0.572</td><td>0.569</td><td>0.570</td><td>0.570</td></tr> <tr><td>0.564</td><td>0.571</td><td>0.569</td><td>0.573</td><td>0.571</td><td>0.573</td><td>0.576</td><td>0.575</td><td>0.576</td><td>0.581</td></tr> <tr><td>0.560</td><td>0.5</td><td>0.570</td><td>0.575</td><td>0.577</td><td>0.574</td><td>0.575</td><td>0.574</td><td>0.574</td><td></td></tr> <tr><td>0.565</td><td>0.5</td><td>0.569</td><td>0.574</td><td>0.577</td><td>0.578</td><td>0.578</td><td>0.572</td><td>0.567</td><td></td></tr> <tr><td>0.561</td><td>0.565</td><td>0.567</td><td>0.565</td><td>0.570</td><td>0.573</td><td>0.569</td><td>0.569</td><td>0.567</td><td>0.563</td></tr> <tr><td>0.553</td><td>0.563</td><td>0.571</td><td>0.571</td><td>0.562</td><td>0.549</td><td>0.564</td><td>0.564</td><td>0.562</td><td>0.562</td></tr> <tr><td>0.551</td><td>0.557</td><td>0.568</td><td>0.566</td><td>0.560</td><td>0.562</td><td>0.563</td><td>0.553</td><td>0.553</td><td>0.555</td></tr> <tr><td>0.547</td><td>0.553</td><td>0.558</td><td>0.553</td><td>0.551</td><td>0.556</td><td>0.554</td><td>0.555</td><td>0.549</td><td>0.548</td></tr> </table>					0.582	0.580	0.572	0.571	0.568	0.570	0.572	0.573	0.563	0.579	0.566	0.561	0.561	0.565	0.564	0.565	0.572	0.569	0.570	0.570	0.564	0.571	0.569	0.573	0.571	0.573	0.576	0.575	0.576	0.581	0.560	0.5	0.570	0.575	0.577	0.574	0.575	0.574	0.574		0.565	0.5	0.569	0.574	0.577	0.578	0.578	0.572	0.567		0.561	0.565	0.567	0.565	0.570	0.573	0.569	0.569	0.567	0.563	0.553	0.563	0.571	0.571	0.562	0.549	0.564	0.564	0.562	0.562	0.551	0.557	0.568	0.566	0.560	0.562	0.563	0.553	0.553	0.555	0.547	0.553	0.558	0.553	0.551	0.556	0.554	0.555	0.549	0.548	<table border="1"> <tr><td>0.558</td><td>0.557</td><td>0.556</td><td>0.517</td><td>0.499</td><td>0.503</td><td>0.540</td><td>0.533</td><td>0.554</td><td>0.561</td></tr> <tr><td>0.556</td><td>0.556</td><td>0.556</td><td>0.551</td><td>0.529</td><td>0.534</td><td>0.532</td><td>0.543</td><td>0.553</td><td>0.555</td></tr> <tr><td>0.553</td><td>0.553</td><td>0.556</td><td>0.552</td><td>0.551</td><td>0.551</td><td>0.551</td><td>0.555</td><td>0.559</td><td>0.563</td></tr> <tr><td>0.549</td><td>0.5</td><td>0.554</td><td>0.552</td><td>0.551</td><td>0.552</td><td>0.551</td><td>0.555</td><td>0.559</td><td></td></tr> <tr><td>0.551</td><td>0.5</td><td>0.552</td><td>0.549</td><td>0.550</td><td>0.551</td><td>0.549</td><td>0.555</td><td>0.559</td><td></td></tr> <tr><td>0.541</td><td>0.54</td><td>0.550</td><td>0.552</td><td>0.549</td><td>0.550</td><td>0.553</td><td>0.551</td><td>0.558</td><td>0.564</td></tr> <tr><td>0.547</td><td>0.551</td><td>0.551</td><td>0.549</td><td>0.553</td><td>0.556</td><td>0.554</td><td>0.556</td><td>0.558</td><td>0.560</td></tr> <tr><td>0.545</td><td>0.547</td><td>0.552</td><td>0.553</td><td>0.556</td><td>0.557</td><td>0.559</td><td>0.558</td><td>0.559</td><td>0.562</td></tr> <tr><td>0.547</td><td>0.543</td><td>0.547</td><td>0.555</td><td>0.550</td><td>0.555</td><td>0.559</td><td>0.557</td><td>0.558</td><td>0.559</td></tr> </table>					0.558	0.557	0.556	0.517	0.499	0.503	0.540	0.533	0.554	0.561	0.556	0.556	0.556	0.551	0.529	0.534	0.532	0.543	0.553	0.555	0.553	0.553	0.556	0.552	0.551	0.551	0.551	0.555	0.559	0.563	0.549	0.5	0.554	0.552	0.551	0.552	0.551	0.555	0.559		0.551	0.5	0.552	0.549	0.550	0.551	0.549	0.555	0.559		0.541	0.54	0.550	0.552	0.549	0.550	0.553	0.551	0.558	0.564	0.547	0.551	0.551	0.549	0.553	0.556	0.554	0.556	0.558	0.560	0.545	0.547	0.552	0.553	0.556	0.557	0.559	0.558	0.559	0.562	0.547	0.543	0.547	0.555	0.550	0.555	0.559	0.557	0.558	0.559
0.583	0.575	0.576	0.560	0.551	0.551	0.571	0.577	0.569	0.569																																																																																																																																																																																																																																																																															
0.579	0.571	0.560	0.560	0.559	0.567	0.573	0.580	0.572	0.562																																																																																																																																																																																																																																																																															
0.575	0.5	0.573	0.570	0.567	0.572	0.571	0.572	0.569	0.563																																																																																																																																																																																																																																																																															
0.563	0.5	0.564	0.568	0.573	0.569	0.570	0.563	0.561																																																																																																																																																																																																																																																																																
0.560	0.5	0.560	0.568	0.571	0.566	0.563	0.561	0.550																																																																																																																																																																																																																																																																																
0.562	0.5	0.562	0.567	0.568	0.567	0.564	0.562	0.555	0.550																																																																																																																																																																																																																																																																															
0.559	0.559	0.565	0.563	0.554	0.538	0.553	0.553	0.552	0.550																																																																																																																																																																																																																																																																															
0.545	0.556	0.559	0.560	0.558	0.557	0.560	0.556	0.551	0.544																																																																																																																																																																																																																																																																															
0.544	0.550	0.553	0.558	0.559	0.557	0.557	0.559	0.553	0.548																																																																																																																																																																																																																																																																															
0.582	0.580	0.572	0.571	0.568	0.570	0.572	0.573	0.563	0.579																																																																																																																																																																																																																																																																															
0.566	0.561	0.561	0.565	0.564	0.565	0.572	0.569	0.570	0.570																																																																																																																																																																																																																																																																															
0.564	0.571	0.569	0.573	0.571	0.573	0.576	0.575	0.576	0.581																																																																																																																																																																																																																																																																															
0.560	0.5	0.570	0.575	0.577	0.574	0.575	0.574	0.574																																																																																																																																																																																																																																																																																
0.565	0.5	0.569	0.574	0.577	0.578	0.578	0.572	0.567																																																																																																																																																																																																																																																																																
0.561	0.565	0.567	0.565	0.570	0.573	0.569	0.569	0.567	0.563																																																																																																																																																																																																																																																																															
0.553	0.563	0.571	0.571	0.562	0.549	0.564	0.564	0.562	0.562																																																																																																																																																																																																																																																																															
0.551	0.557	0.568	0.566	0.560	0.562	0.563	0.553	0.553	0.555																																																																																																																																																																																																																																																																															
0.547	0.553	0.558	0.553	0.551	0.556	0.554	0.555	0.549	0.548																																																																																																																																																																																																																																																																															
0.558	0.557	0.556	0.517	0.499	0.503	0.540	0.533	0.554	0.561																																																																																																																																																																																																																																																																															
0.556	0.556	0.556	0.551	0.529	0.534	0.532	0.543	0.553	0.555																																																																																																																																																																																																																																																																															
0.553	0.553	0.556	0.552	0.551	0.551	0.551	0.555	0.559	0.563																																																																																																																																																																																																																																																																															
0.549	0.5	0.554	0.552	0.551	0.552	0.551	0.555	0.559																																																																																																																																																																																																																																																																																
0.551	0.5	0.552	0.549	0.550	0.551	0.549	0.555	0.559																																																																																																																																																																																																																																																																																
0.541	0.54	0.550	0.552	0.549	0.550	0.553	0.551	0.558	0.564																																																																																																																																																																																																																																																																															
0.547	0.551	0.551	0.549	0.553	0.556	0.554	0.556	0.558	0.560																																																																																																																																																																																																																																																																															
0.545	0.547	0.552	0.553	0.556	0.557	0.559	0.558	0.559	0.562																																																																																																																																																																																																																																																																															
0.547	0.543	0.547	0.555	0.550	0.555	0.559	0.557	0.558	0.559																																																																																																																																																																																																																																																																															

(二) 橋墩前方泥沙上升或下降情形-正值為上升，負值為下降；排列方式正三角形即頂角朝向與河川流向為 180 度夾角，排列方式倒三角形即頂角朝向與河川流向一致。

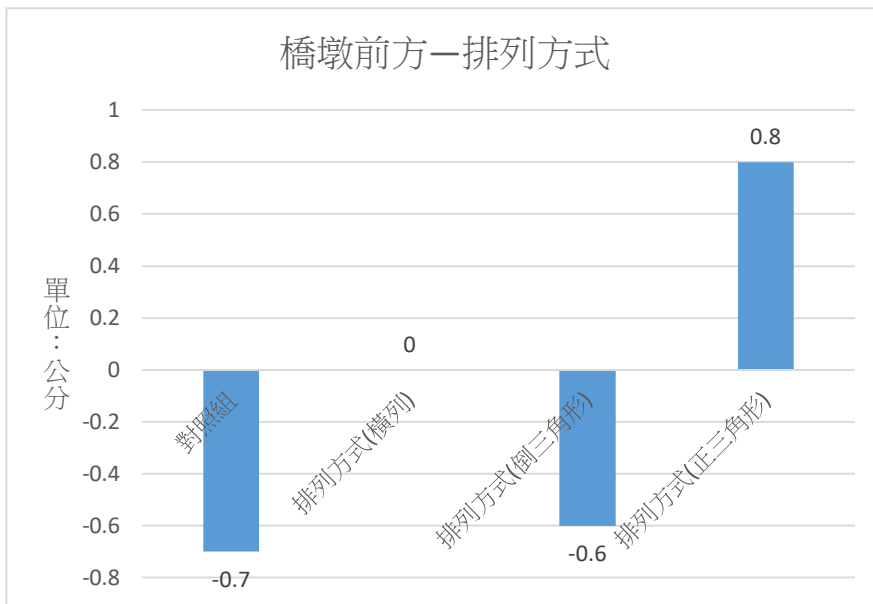

(三) 流經兩個光電傳感器所需時間

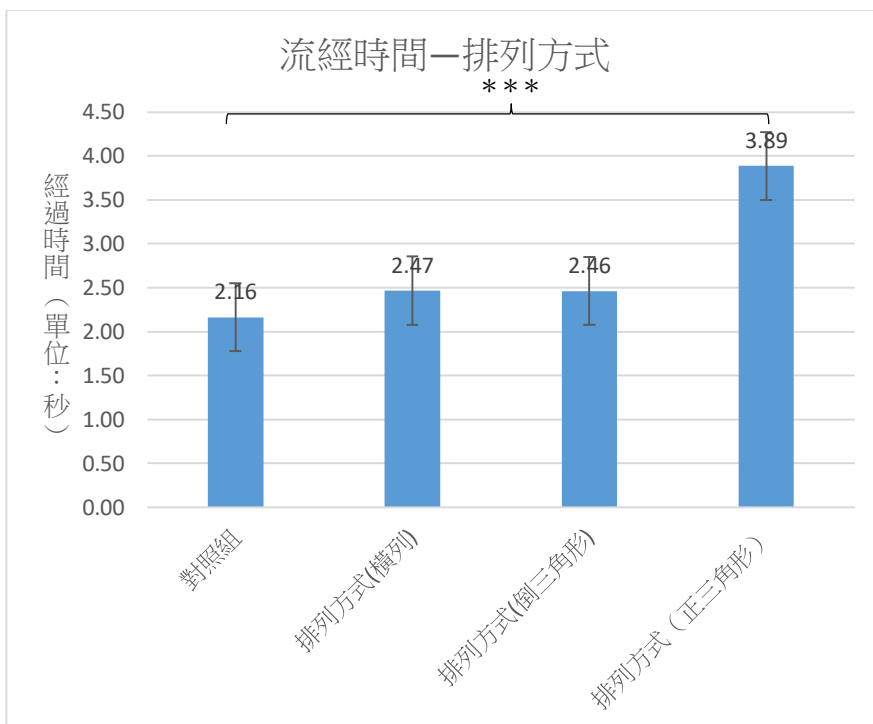

(四) 討論

針對葉片的裝置排列，我們也做了不同的比較：在最初構想當中，我們讓葉片裝置面對水呈現三角形排列，另外又進行了葉片橫列狀安置以及倒三角形安置的比較，也因前項實驗中，得出三角形葉片抵擋流速的效果最佳，因此再深入探討若是改變其排列方式會對河流侵蝕造成何種影響，從橋墩前方侵蝕狀況可發現正三角形（頂角朝向水流來向）的排列方式

不僅能阻擋侵蝕，更能產生堆積，也是最能減緩流速的方式，而倒三角形（對邊朝向水流來向）的排列方式中，橋墩前方被侵蝕的最多。

探究其原因，水流情形可能如下表所示，倒三角形的排列方式可能因會將水流更為集中在橋墩附近，造成橋墩附近水流碰撞變多，進而導致更多渦流產生而侵蝕，就如同橋墩後方會形成消散渦流一般，倒三角形的排列或是橫列的排列，在水流經過之後雖然被三角形小葉片切割，但是仍然會匯聚，甚至在到達橋墩時水流又因匯聚而變回大而快速的水流，這或許也是為何其減緩流速的程度與橫列排法相近，但橋墩前方的侵蝕狀況卻最嚴重，且橋墩後方的地形也明顯下降，反之，正三角形（頂角朝向水流來向）的排列方式能協助水流進行導流，使其效果最佳，可能是因本身已經如同我們常見的沙洲一般，將部分水流往兩旁引導，使其改變流向（當然因為葉片的關係，也有一部分水能夠穿透葉片的縫隙），在到達橋墩之前，水流並沒有完全聚合，也就是葉片設置區以及橋墩之間成為「安定地帶」，水流仍然較緩慢。

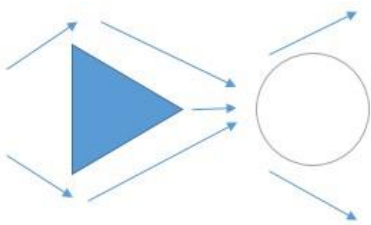
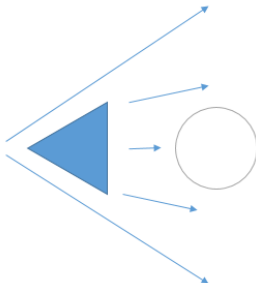
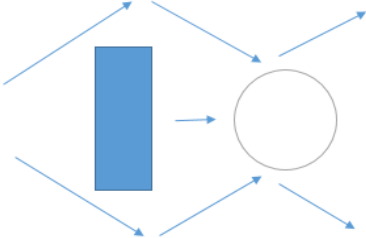
倒三角形 (對邊朝向水流來向)	正三角形 (頂角朝向水流來向)	橫列 (與河川流向垂直)
		

三、探討不同環圈頂角的柔性葉片環圈減少河道侵蝕的功效

(一) 地形圖-白色圓形圖示為橋墩，藍色圖示為保護工。

對照組																																																																																																																																																																																																																																																																																																																																																																														
<table border="1"> <tr><td>0.576</td><td>0.575</td><td>0.57</td><td>0.565</td><td>0.566</td><td>0.564</td><td>0.56</td><td>0.571</td><td>0.573</td><td>0.569</td></tr> <tr><td>0.578</td><td>0.577</td><td>0.568</td><td>0.557</td><td>0.539</td><td>0.523</td><td>0.566</td><td>0.578</td><td>0.58</td><td>0.576</td></tr> <tr><td>0.572</td><td>0.572</td><td>0.564</td><td>0.559</td><td>0.558</td><td>0.56</td><td>0.56</td><td>0.575</td><td>0.575</td><td>0.575</td></tr> <tr><td>0.57</td><td>0.566</td><td>0.559</td><td>0.56</td><td>0.562</td><td>0.566</td><td>0.569</td><td>0.572</td><td>0.574</td><td></td></tr> <tr><td>0.562</td><td>0.561</td><td>0.558</td><td>0.55</td><td>0.563</td><td>0.565</td><td>0.57</td><td>0.572</td><td>0.572</td><td></td></tr> <tr><td>0.565</td><td>0.558</td><td>0.554</td><td>0.559</td><td>0.562</td><td>0.563</td><td>0.565</td><td>0.566</td><td>0.574</td><td>0.576</td></tr> <tr><td>0.562</td><td>0.559</td><td>0.56</td><td>0.554</td><td>0.554</td><td>0.558</td><td>0.566</td><td>0.567</td><td>0.57</td><td>0.574</td></tr> <tr><td>0.559</td><td>0.554</td><td>0.551</td><td>0.553</td><td>0.558</td><td>0.56</td><td>0.554</td><td>0.56</td><td>0.564</td><td>0.566</td></tr> <tr><td>0.557</td><td>0.553</td><td>0.55</td><td>0.551</td><td>0.553</td><td>0.557</td><td>0.555</td><td>0.56</td><td>0.564</td><td>0.568</td></tr> </table>																	0.576	0.575	0.57	0.565	0.566	0.564	0.56	0.571	0.573	0.569	0.578	0.577	0.568	0.557	0.539	0.523	0.566	0.578	0.58	0.576	0.572	0.572	0.564	0.559	0.558	0.56	0.56	0.575	0.575	0.575	0.57	0.566	0.559	0.56	0.562	0.566	0.569	0.572	0.574		0.562	0.561	0.558	0.55	0.563	0.565	0.57	0.572	0.572		0.565	0.558	0.554	0.559	0.562	0.563	0.565	0.566	0.574	0.576	0.562	0.559	0.56	0.554	0.554	0.558	0.566	0.567	0.57	0.574	0.559	0.554	0.551	0.553	0.558	0.56	0.554	0.56	0.564	0.566	0.557	0.553	0.55	0.551	0.553	0.557	0.555	0.56	0.564	0.568																																																																																																																																																																																																																																																																				
0.576	0.575	0.57	0.565	0.566	0.564	0.56	0.571	0.573	0.569																																																																																																																																																																																																																																																																																																																																																																					
0.578	0.577	0.568	0.557	0.539	0.523	0.566	0.578	0.58	0.576																																																																																																																																																																																																																																																																																																																																																																					
0.572	0.572	0.564	0.559	0.558	0.56	0.56	0.575	0.575	0.575																																																																																																																																																																																																																																																																																																																																																																					
0.57	0.566	0.559	0.56	0.562	0.566	0.569	0.572	0.574																																																																																																																																																																																																																																																																																																																																																																						
0.562	0.561	0.558	0.55	0.563	0.565	0.57	0.572	0.572																																																																																																																																																																																																																																																																																																																																																																						
0.565	0.558	0.554	0.559	0.562	0.563	0.565	0.566	0.574	0.576																																																																																																																																																																																																																																																																																																																																																																					
0.562	0.559	0.56	0.554	0.554	0.558	0.566	0.567	0.57	0.574																																																																																																																																																																																																																																																																																																																																																																					
0.559	0.554	0.551	0.553	0.558	0.56	0.554	0.56	0.564	0.566																																																																																																																																																																																																																																																																																																																																																																					
0.557	0.553	0.55	0.551	0.553	0.557	0.555	0.56	0.564	0.568																																																																																																																																																																																																																																																																																																																																																																					
45度				60度				90度				135度																																																																																																																																																																																																																																																																																																																																																																		
<table border="1"> <tr><td>0.558</td><td>0.574</td><td>0.562</td><td>0.535</td><td>0.526</td><td>0.556</td><td>0.567</td><td>0.572</td><td>0.579</td><td>0.581</td></tr> <tr><td>0.568</td><td>0.565</td><td>0.550</td><td>0.548</td><td>0.549</td><td>0.561</td><td>0.564</td><td>0.572</td><td>0.581</td><td>0.578</td></tr> <tr><td>0.567</td><td>0.564</td><td>0.560</td><td>0.555</td><td>0.568</td><td>0.562</td><td>0.568</td><td>0.566</td><td>0.570</td><td>0.577</td></tr> <tr><td>0.567</td><td>0.571</td><td>0.566</td><td>0.573</td><td>0.568</td><td>0.569</td><td>0.570</td><td>0.574</td><td></td><td></td></tr> <tr><td>0.559</td><td>0.563</td><td>0.563</td><td>0.563</td><td>0.564</td><td>0.564</td><td>0.567</td><td>0.573</td><td>0.578</td><td></td></tr> <tr><td>0.557</td><td>0.556</td><td>0.553</td><td>0.552</td><td>0.549</td><td>0.554</td><td>0.550</td><td>0.558</td><td>0.563</td><td>0.571</td></tr> <tr><td>0.552</td><td>0.549</td><td>0.549</td><td>0.546</td><td>0.548</td><td>0.551</td><td>0.553</td><td>0.557</td><td>0.563</td><td>0.567</td></tr> <tr><td>0.537</td><td>0.542</td><td>0.544</td><td>0.543</td><td>0.545</td><td>0.547</td><td>0.551</td><td>0.556</td><td>0.563</td><td>0.567</td></tr> </table>				0.558	0.574	0.562	0.535	0.526	0.556	0.567	0.572	0.579	0.581	0.568	0.565	0.550	0.548	0.549	0.561	0.564	0.572	0.581	0.578	0.567	0.564	0.560	0.555	0.568	0.562	0.568	0.566	0.570	0.577	0.567	0.571	0.566	0.573	0.568	0.569	0.570	0.574			0.559	0.563	0.563	0.563	0.564	0.564	0.567	0.573	0.578		0.557	0.556	0.553	0.552	0.549	0.554	0.550	0.558	0.563	0.571	0.552	0.549	0.549	0.546	0.548	0.551	0.553	0.557	0.563	0.567	0.537	0.542	0.544	0.543	0.545	0.547	0.551	0.556	0.563	0.567	<table border="1"> <tr><td>0.558</td><td>0.557</td><td>0.556</td><td>0.517</td><td>0.499</td><td>0.503</td><td>0.540</td><td>0.533</td><td>0.554</td><td>0.561</td></tr> <tr><td>0.556</td><td>0.556</td><td>0.556</td><td>0.551</td><td>0.529</td><td>0.534</td><td>0.532</td><td>0.543</td><td>0.553</td><td>0.555</td></tr> <tr><td>0.553</td><td>0.553</td><td>0.556</td><td>0.552</td><td>0.551</td><td>0.551</td><td>0.551</td><td>0.555</td><td>0.559</td><td>0.563</td></tr> <tr><td>0.549</td><td>0.547</td><td>0.554</td><td>0.552</td><td>0.551</td><td>0.552</td><td>0.551</td><td>0.555</td><td>0.559</td><td></td></tr> <tr><td>0.551</td><td>0.549</td><td>0.552</td><td>0.549</td><td>0.550</td><td>0.551</td><td>0.549</td><td>0.555</td><td>0.559</td><td></td></tr> <tr><td>0.541</td><td>0.541</td><td>0.550</td><td>0.552</td><td>0.549</td><td>0.550</td><td>0.553</td><td>0.551</td><td>0.558</td><td>0.564</td></tr> <tr><td>0.547</td><td>0.551</td><td>0.551</td><td>0.549</td><td>0.553</td><td>0.556</td><td>0.554</td><td>0.556</td><td>0.558</td><td>0.560</td></tr> <tr><td>0.545</td><td>0.547</td><td>0.552</td><td>0.553</td><td>0.556</td><td>0.557</td><td>0.559</td><td>0.558</td><td>0.559</td><td>0.562</td></tr> <tr><td>0.547</td><td>0.543</td><td>0.547</td><td>0.555</td><td>0.550</td><td>0.555</td><td>0.559</td><td>0.557</td><td>0.558</td><td>0.559</td></tr> </table>				0.558	0.557	0.556	0.517	0.499	0.503	0.540	0.533	0.554	0.561	0.556	0.556	0.556	0.551	0.529	0.534	0.532	0.543	0.553	0.555	0.553	0.553	0.556	0.552	0.551	0.551	0.551	0.555	0.559	0.563	0.549	0.547	0.554	0.552	0.551	0.552	0.551	0.555	0.559		0.551	0.549	0.552	0.549	0.550	0.551	0.549	0.555	0.559		0.541	0.541	0.550	0.552	0.549	0.550	0.553	0.551	0.558	0.564	0.547	0.551	0.551	0.549	0.553	0.556	0.554	0.556	0.558	0.560	0.545	0.547	0.552	0.553	0.556	0.557	0.559	0.558	0.559	0.562	0.547	0.543	0.547	0.555	0.550	0.555	0.559	0.557	0.558	0.559	<table border="1"> <tr><td>0.578</td><td>0.578</td><td>0.567</td><td>0.555</td><td>0.533</td><td>0.519</td><td>0.547</td><td>0.565</td><td>0.577</td><td>0.588</td></tr> <tr><td>0.579</td><td>0.574</td><td>0.559</td><td>0.551</td><td>0.555</td><td>0.564</td><td>0.567</td><td>0.573</td><td>0.578</td><td>0.576</td></tr> <tr><td>0.579</td><td>0.574</td><td>0.567</td><td>0.563</td><td>0.566</td><td>0.563</td><td>0.564</td><td>0.566</td><td>0.569</td><td>0.576</td></tr> <tr><td>0.574</td><td>0.571</td><td>0.568</td><td>0.572</td><td>0.567</td><td>0.569</td><td>0.570</td><td>0.571</td><td>0.571</td><td>0.571</td></tr> <tr><td>0.570</td><td>0.570</td><td>0.571</td><td>0.571</td><td>0.571</td><td>0.571</td><td>0.571</td><td>0.571</td><td>0.571</td><td>0.571</td></tr> <tr><td>0.567</td><td>0.570</td><td>0.566</td><td>0.565</td><td>0.570</td><td>0.571</td><td>0.565</td><td>0.567</td><td>0.568</td><td>0.571</td></tr> <tr><td>0.559</td><td>0.562</td><td>0.559</td><td>0.564</td><td>0.560</td><td>0.558</td><td>0.556</td><td>0.564</td><td>0.566</td><td>0.567</td></tr> <tr><td>0.557</td><td>0.557</td><td>0.559</td><td>0.556</td><td>0.558</td><td>0.560</td><td>0.562</td><td>0.566</td><td>0.568</td><td>0.573</td></tr> <tr><td>0.555</td><td>0.554</td><td>0.557</td><td>0.554</td><td>0.557</td><td>0.559</td><td>0.560</td><td>0.561</td><td>0.568</td><td>0.570</td></tr> </table>				0.578	0.578	0.567	0.555	0.533	0.519	0.547	0.565	0.577	0.588	0.579	0.574	0.559	0.551	0.555	0.564	0.567	0.573	0.578	0.576	0.579	0.574	0.567	0.563	0.566	0.563	0.564	0.566	0.569	0.576	0.574	0.571	0.568	0.572	0.567	0.569	0.570	0.571	0.571	0.571	0.570	0.570	0.571	0.571	0.571	0.571	0.571	0.571	0.571	0.571	0.567	0.570	0.566	0.565	0.570	0.571	0.565	0.567	0.568	0.571	0.559	0.562	0.559	0.564	0.560	0.558	0.556	0.564	0.566	0.567	0.557	0.557	0.559	0.556	0.558	0.560	0.562	0.566	0.568	0.573	0.555	0.554	0.557	0.554	0.557	0.559	0.560	0.561	0.568	0.570	<table border="1"> <tr><td>0.572</td><td>0.570</td><td>0.560</td><td>0.551</td><td>0.526</td><td>0.542</td><td>0.558</td><td>0.563</td><td>0.565</td><td>0.573</td></tr> <tr><td>0.568</td><td>0.567</td><td>0.564</td><td>0.569</td><td>0.562</td><td>0.566</td><td>0.564</td><td>0.565</td><td>0.567</td><td>0.576</td></tr> <tr><td>0.570</td><td>0.568</td><td>0.564</td><td>0.564</td><td>0.563</td><td>0.558</td><td>0.566</td><td>0.561</td><td>0.565</td><td>0.564</td></tr> <tr><td>0.572</td><td>0.571</td><td>0.564</td><td>0.560</td><td>0.564</td><td>0.562</td><td>0.569</td><td>0.568</td><td>0.566</td><td></td></tr> <tr><td>0.566</td><td>0.562</td><td>0.564</td><td>0.564</td><td>0.564</td><td>0.565</td><td>0.568</td><td>0.571</td><td>0.571</td><td></td></tr> <tr><td>0.567</td><td>0.568</td><td>0.562</td><td>0.562</td><td>0.562</td><td>0.562</td><td>0.562</td><td>0.563</td><td>0.564</td><td>0.568</td></tr> <tr><td>0.564</td><td>0.568</td><td>0.554</td><td>0.555</td><td>0.550</td><td>0.552</td><td>0.553</td><td>0.564</td><td>0.556</td><td>0.557</td></tr> <tr><td>0.566</td><td>0.565</td><td>0.555</td><td>0.558</td><td>0.551</td><td>0.549</td><td>0.551</td><td>0.556</td><td>0.560</td><td>0.562</td></tr> <tr><td>0.553</td><td>0.557</td><td>0.553</td><td>0.551</td><td>0.549</td><td>0.550</td><td>0.550</td><td>0.548</td><td>0.553</td><td>0.553</td></tr> </table>					0.572	0.570	0.560	0.551	0.526	0.542	0.558	0.563	0.565	0.573	0.568	0.567	0.564	0.569	0.562	0.566	0.564	0.565	0.567	0.576	0.570	0.568	0.564	0.564	0.563	0.558	0.566	0.561	0.565	0.564	0.572	0.571	0.564	0.560	0.564	0.562	0.569	0.568	0.566		0.566	0.562	0.564	0.564	0.564	0.565	0.568	0.571	0.571		0.567	0.568	0.562	0.562	0.562	0.562	0.562	0.563	0.564	0.568	0.564	0.568	0.554	0.555	0.550	0.552	0.553	0.564	0.556	0.557	0.566	0.565	0.555	0.558	0.551	0.549	0.551	0.556	0.560	0.562	0.553	0.557	0.553	0.551	0.549	0.550	0.550	0.548	0.553	0.553
0.558	0.574	0.562	0.535	0.526	0.556	0.567	0.572	0.579	0.581																																																																																																																																																																																																																																																																																																																																																																					
0.568	0.565	0.550	0.548	0.549	0.561	0.564	0.572	0.581	0.578																																																																																																																																																																																																																																																																																																																																																																					
0.567	0.564	0.560	0.555	0.568	0.562	0.568	0.566	0.570	0.577																																																																																																																																																																																																																																																																																																																																																																					
0.567	0.571	0.566	0.573	0.568	0.569	0.570	0.574																																																																																																																																																																																																																																																																																																																																																																							
0.559	0.563	0.563	0.563	0.564	0.564	0.567	0.573	0.578																																																																																																																																																																																																																																																																																																																																																																						
0.557	0.556	0.553	0.552	0.549	0.554	0.550	0.558	0.563	0.571																																																																																																																																																																																																																																																																																																																																																																					
0.552	0.549	0.549	0.546	0.548	0.551	0.553	0.557	0.563	0.567																																																																																																																																																																																																																																																																																																																																																																					
0.537	0.542	0.544	0.543	0.545	0.547	0.551	0.556	0.563	0.567																																																																																																																																																																																																																																																																																																																																																																					
0.558	0.557	0.556	0.517	0.499	0.503	0.540	0.533	0.554	0.561																																																																																																																																																																																																																																																																																																																																																																					
0.556	0.556	0.556	0.551	0.529	0.534	0.532	0.543	0.553	0.555																																																																																																																																																																																																																																																																																																																																																																					
0.553	0.553	0.556	0.552	0.551	0.551	0.551	0.555	0.559	0.563																																																																																																																																																																																																																																																																																																																																																																					
0.549	0.547	0.554	0.552	0.551	0.552	0.551	0.555	0.559																																																																																																																																																																																																																																																																																																																																																																						
0.551	0.549	0.552	0.549	0.550	0.551	0.549	0.555	0.559																																																																																																																																																																																																																																																																																																																																																																						
0.541	0.541	0.550	0.552	0.549	0.550	0.553	0.551	0.558	0.564																																																																																																																																																																																																																																																																																																																																																																					
0.547	0.551	0.551	0.549	0.553	0.556	0.554	0.556	0.558	0.560																																																																																																																																																																																																																																																																																																																																																																					
0.545	0.547	0.552	0.553	0.556	0.557	0.559	0.558	0.559	0.562																																																																																																																																																																																																																																																																																																																																																																					
0.547	0.543	0.547	0.555	0.550	0.555	0.559	0.557	0.558	0.559																																																																																																																																																																																																																																																																																																																																																																					
0.578	0.578	0.567	0.555	0.533	0.519	0.547	0.565	0.577	0.588																																																																																																																																																																																																																																																																																																																																																																					
0.579	0.574	0.559	0.551	0.555	0.564	0.567	0.573	0.578	0.576																																																																																																																																																																																																																																																																																																																																																																					
0.579	0.574	0.567	0.563	0.566	0.563	0.564	0.566	0.569	0.576																																																																																																																																																																																																																																																																																																																																																																					
0.574	0.571	0.568	0.572	0.567	0.569	0.570	0.571	0.571	0.571																																																																																																																																																																																																																																																																																																																																																																					
0.570	0.570	0.571	0.571	0.571	0.571	0.571	0.571	0.571	0.571																																																																																																																																																																																																																																																																																																																																																																					
0.567	0.570	0.566	0.565	0.570	0.571	0.565	0.567	0.568	0.571																																																																																																																																																																																																																																																																																																																																																																					
0.559	0.562	0.559	0.564	0.560	0.558	0.556	0.564	0.566	0.567																																																																																																																																																																																																																																																																																																																																																																					
0.557	0.557	0.559	0.556	0.558	0.560	0.562	0.566	0.568	0.573																																																																																																																																																																																																																																																																																																																																																																					
0.555	0.554	0.557	0.554	0.557	0.559	0.560	0.561	0.568	0.570																																																																																																																																																																																																																																																																																																																																																																					
0.572	0.570	0.560	0.551	0.526	0.542	0.558	0.563	0.565	0.573																																																																																																																																																																																																																																																																																																																																																																					
0.568	0.567	0.564	0.569	0.562	0.566	0.564	0.565	0.567	0.576																																																																																																																																																																																																																																																																																																																																																																					
0.570	0.568	0.564	0.564	0.563	0.558	0.566	0.561	0.565	0.564																																																																																																																																																																																																																																																																																																																																																																					
0.572	0.571	0.564	0.560	0.564	0.562	0.569	0.568	0.566																																																																																																																																																																																																																																																																																																																																																																						
0.566	0.562	0.564	0.564	0.564	0.565	0.568	0.571	0.571																																																																																																																																																																																																																																																																																																																																																																						
0.567	0.568	0.562	0.562	0.562	0.562	0.562	0.563	0.564	0.568																																																																																																																																																																																																																																																																																																																																																																					
0.564	0.568	0.554	0.555	0.550	0.552	0.553	0.564	0.556	0.557																																																																																																																																																																																																																																																																																																																																																																					
0.566	0.565	0.555	0.558	0.551	0.549	0.551	0.556	0.560	0.562																																																																																																																																																																																																																																																																																																																																																																					
0.553	0.557	0.553	0.551	0.549	0.550	0.550	0.548	0.553	0.553																																																																																																																																																																																																																																																																																																																																																																					

(二) 橋墩前方泥沙上升或下降情形-正值為上升，負值為下降。

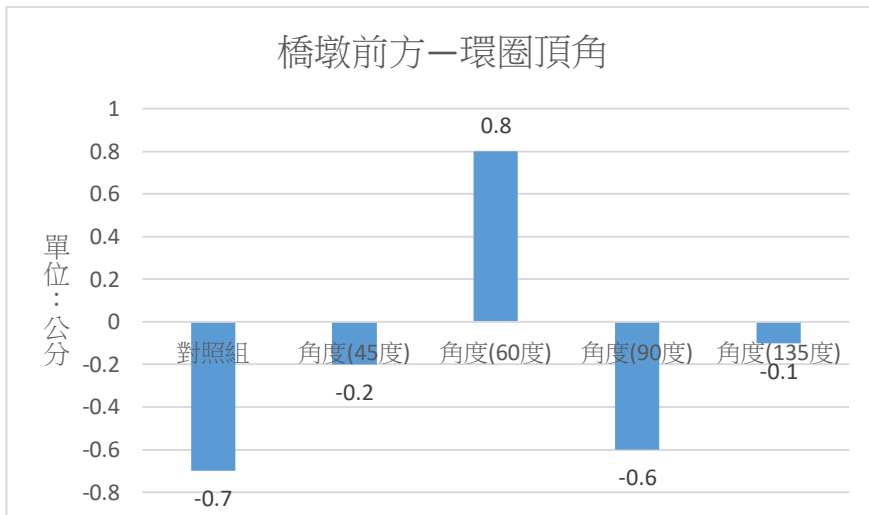

(三) 流經兩個光電傳感器所需時間

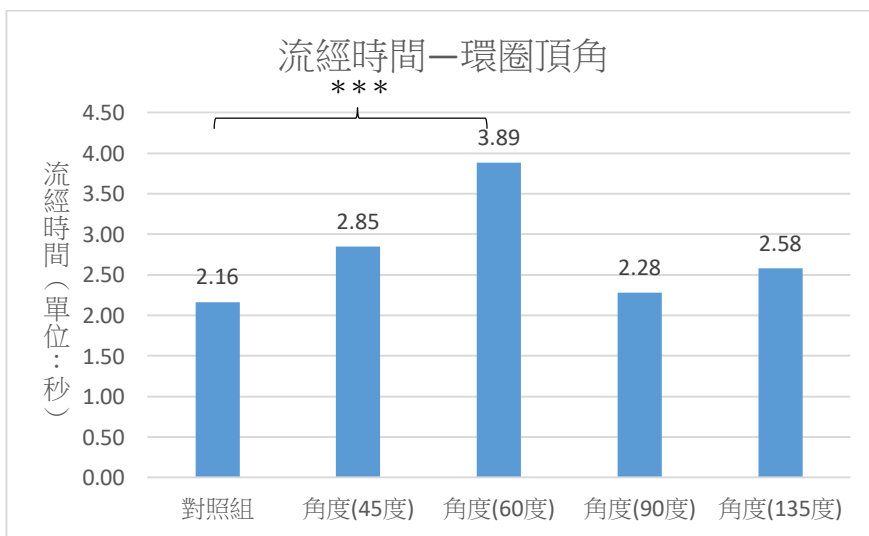

(四) 討論

定調使用正三角形排列方式之後，我們也試圖調整排列的頂角，並延用效用最佳的三角形葉片。其結果，以我們的葉片形狀和密度，面對水流呈現六十度角時，效果會最好。在我們所做的角度當中，雖然並沒有做出每一個可能的角度，然而我們可以看到兩項趨勢：若是夾角太小，雖然形成分流，但是兩側的角度不夠，水流到橋墩時減速和分流的效果並沒有那麼樣的好。而若是夾角太大，分流的效果並不明顯，那麼就近似於前一項實驗的橫列型裝置了。因此我們認為這葉片的排列方式必須呈現一個角度，而這角度可能和橋墩的大小以及安置區以及橋墩的距離有關，可以視情況做調整。

四、比較消波塊與柔性葉片環圈減少河道侵蝕的功效

(一) 地形圖-白色圓形圖示為橋墩，藍色圖示為保護工。

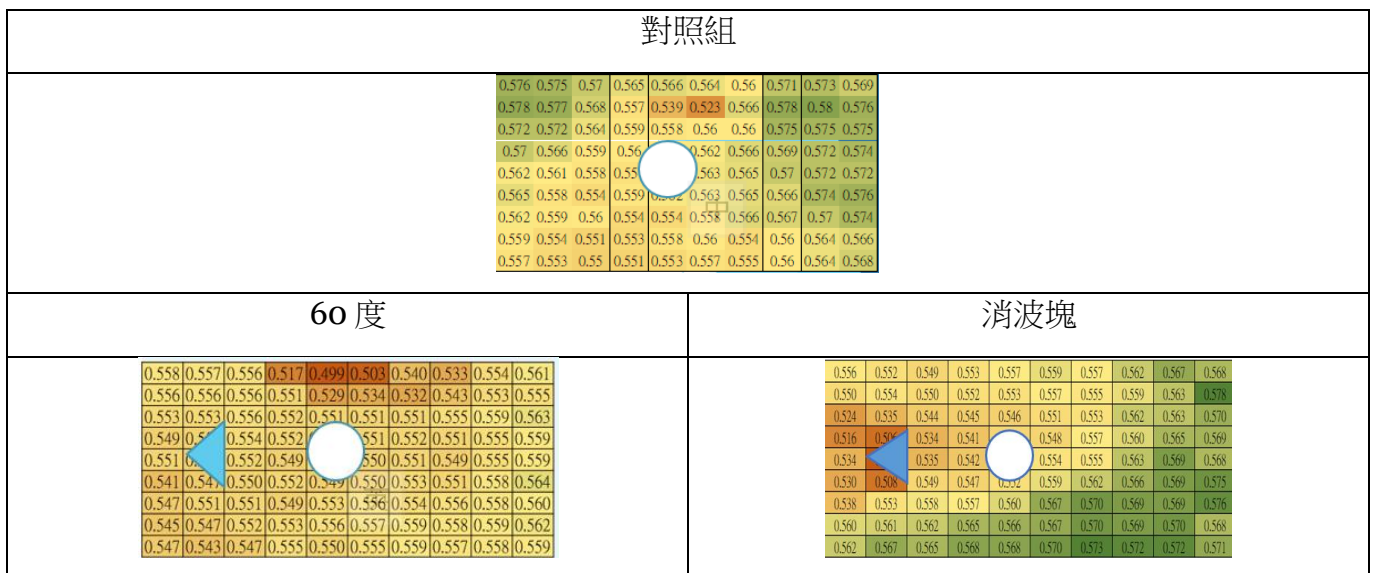

(二) 橋墩前方泥沙上升或下降情形-正值為上升，負值為下降。

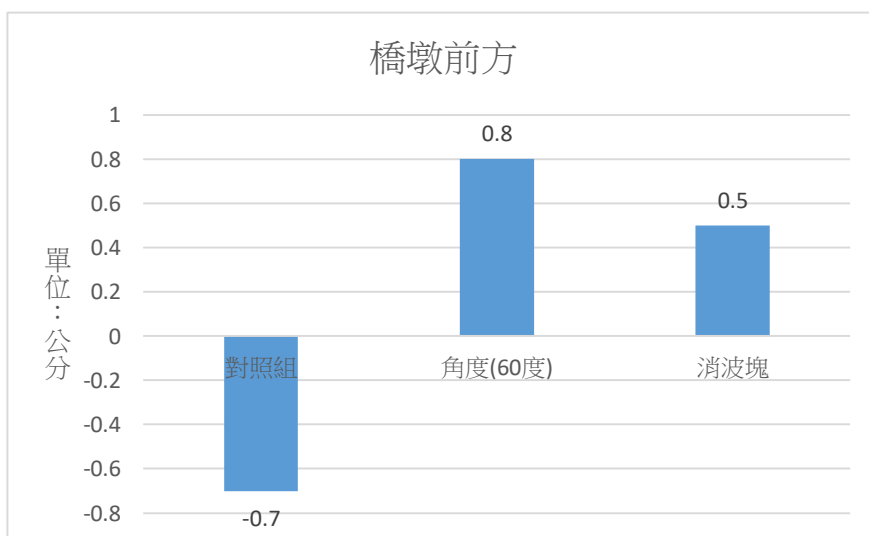

(三) 流經兩個光電傳感器所需時間

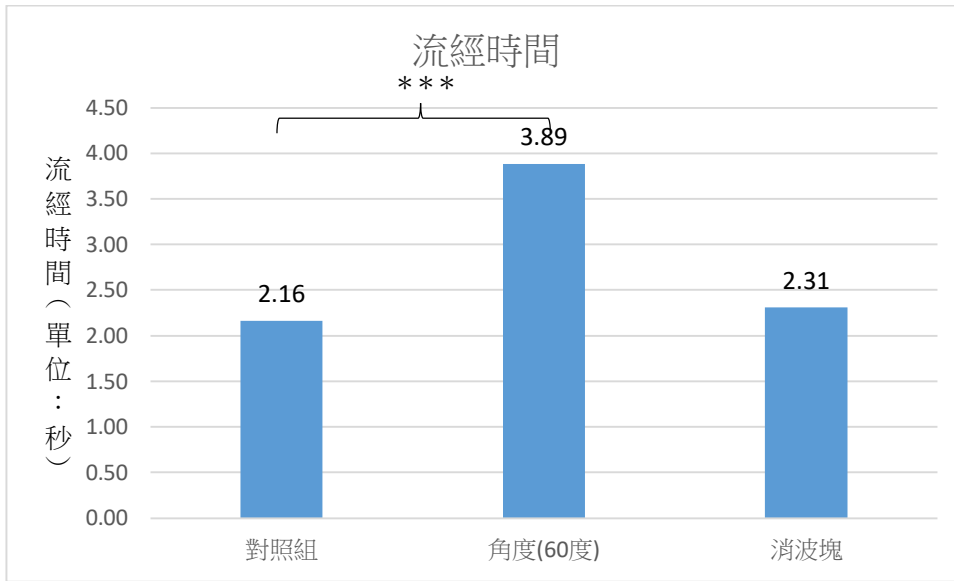

(四) 討論

從圖片中可看出，在消波塊和柔性葉片環圈的個數一樣的情況下，為了讓面積差不多所以排比較密集，消波塊可在橋墩前方形成堆積進而保護橋墩，但是因為消波塊需要擺放的比較密集才有效果，保護的區域較柔性葉片環圈小，因此沒保護到的區域侵蝕較為嚴重，甚至使沒保護到的區域侵蝕更為嚴重。

而比較皆為頂角為 60 度的柔性葉片環圈及消波塊，可以發現消波塊防止橋墩侵蝕的效果比柔性葉片環圈差，因此我們推測在一定程度上，柔性葉片環圈能替代消波塊。

五、綜合討論

(一) 研究目標設定

我們所面對的是橋墩周圍侵蝕的問題，根據水文的常識我們可以知道，在水流當中發生侵蝕、搬運抑或是堆積，取決於兩項條件：一是砂土粒徑的大小，二則是水流的流速。

而在我們的問題當中，我們所面對的是已經建立的橋樑，因此我們無法選擇底質的粒徑大小和土質，因此我們要解決侵蝕的問題，只能從水流的方面著手：改變水流流向或是減緩經過水流的速度，使經過的水流對於砂土盡可能地維持在被搬運的狀態，若是產生堆積，則必須視狀況清除，而產生侵蝕則是我們所最不樂見的。

在橋墩的周圍，除了面對水流的部分會受到侵蝕之外，當水流流過橋墩，分為左右兩道時，對橋墩的側面也可能產生侵蝕作用。另外，在橋墩後方，被橋墩分開的水流會重新聚合，

環繞橋墩形成馬蹄形之渦流（程仕帆，2003）因此甚至在橋墩的後方也有可能產生侵蝕作用，是故，我們在檢驗橋墩周圍的侵蝕時，不只是看迎水面，而是整個橋墩的周圍狀況都要納入考量。

我們所主要探討的方式源自於文獻中所提到的柔性葉片環圈法（彭大雄、徐郁超及詹錢登，2010），利用特殊形狀的沉積物懸掛在橋墩前方，達到切割水流以及減速的目的。在彭的研究當中使用了自由飄動的輪胎等物，但並未針對安置的物體形狀和配置方式進行比較，因此我們的研究由此出發，希望更細項的去探討，何種環圈對於橋墩的侵蝕狀況能夠最佳的改善，如果能夠找到柔性葉片的較佳配置方式和最適形狀，也許就能提升此方式的效率，使之廣泛使用在不同的橋樑保護方面。

（二）沖刷坑的改善：針對橋墩周圍沖刷狀況之表現

使用柔性葉片保護橋墩時，許多組的實驗都可以見到橋墩的後方沖刷狀況較對照組好，甚至在一些實驗組當中出現了橋墩後方沙土堆積的情況，也就是可以證實此種方式對於橋墩沖刷有改善效果，然而也有一些組別並未表現如此趨勢，因此我們認為和葉片的配置有關。從周圍的地形圖來看亦然；在某些配置之中，緊鄰橋墩的附近能觀察到堆積，但是以整體地形來看，卻在距離橋墩有一小段距離的部分產生了沖刷坑，當然水流的匯聚是不可避免，然而若是因流向和流速太快而形成大的沖刷坑，雖不是與橋墩相鄰但也有可能產生不良的影響，因此必須找到較為好的葉片配置和排列方式。（圖二十一及圖二十二）

圖二十一：未安置環圈前的沖刷坑



圖二十二：當安置葉片為三角形保護工時的沖刷坑



（三）切割與分流：柔性葉片的兩種效果

從前方流速的表現來看，能夠找出最佳的組合，以我們的橋墩大小與距離，選用三角形葉片，並呈現三角形排列時，能夠達到最好的效果。三角形葉片本身能切割水流，使之部分轉向、部分從空隙流過。而在排列的實驗當中，我們則發現，使水分流比迎面阻擋效果要好，而朝向水流的三角形排列，夾角 60 度時能夠有較好的分流效果，而這夾角並非越大越好或越小越好。

捌、結論

- 一、柔性葉片能有效的減緩橋墩周圍侵蝕。
- 二、葉片造型選用三角形時，其效果較佳。
- 三、安置環圈時，將其排成頂角面對水流的三角形，成果較佳。可能可以產生分流的效果。
- 四、三角形排列的夾角，應與橋墩之間存在特定比例關係，而非單純越大越好或越小越好。
- 五、推測在一定程度上，柔性葉片環圈能替代消波塊。

玖、參考文獻

- 一、水磨力-水生植物與水流之相關探討。中華民國第 58 屆中小學科學展覽，國中組地球科學科作品。
- 二、彭大雄、徐郁超及詹錢登(2010)。柔性葉片環圈堆保護工應用於橋墩沖刷現地試驗之研究。土木水利，第 37 卷第 2 期，第 63~75 頁。
- 三、王傳益、呂其倫、張詠善及鄭人豪(2012)。環圈柱群於橋墩沖刷防治之研究。農業工程學報，第 58 卷第 4 期，第 51~66 頁。
- 四、程仕帆(2003)。套環保護工法對減少橋墩局部沖刷之研究。國立中央大學土木工程研究所碩士論文。
- 五、林宗儀(2019)。台灣還需要消波塊嗎。科學人雜誌。2020 年 6 月 3 日，取自：
<https://sa.ylib.com/MagArticle.aspx?Unit=featurearticles&id=4604>

【評語】 030506

研究主題清楚聚焦，科學方法檢驗。有社會有實用價值。有系統收集數據及分析。有清晰圖表及圖例。大致了解結果與結論之釋義及限制。

該作品嘗試提出減緩橋墩侵蝕的設計，尤其採用回收物品(輪胎、鋁片等)來做為設計的材料，探討柔性葉片保護工在橋墩對抗河川侵蝕方面的效能，推測何種環圈的排列方式會有較佳的結果，以減少消波塊使用對環境的影響。這是實用又有意義的研究，對河川的保育工作有正面的意義。

實驗設計有趣，手法具挑戰。同學對於柔性葉片的設計很有想法，並在葉片設計上進行很全面的實驗，這點很值得鼓勵！

但實驗中所使用的是穩定片流，沒有改變流速。並且實際影響橋墩侵蝕的是河道亂流，但這點在實驗中無法呈現，未來可以改進。

壹、摘要

本研究主要目的為探討柔性葉片環圈是否能有效減緩橋墩周圍侵蝕，並要在何種條件下，才能使效果最佳；而本研究運用自製的水道模型，等比例縮小碧潭大橋及柔性葉片保護工，設置不同的葉片形狀、不同環圈排列方式及三角形排列時不同的頂角，會對流速、橋墩周圍侵蝕及周邊地形造成何種影響。

由研究結果可知，柔性葉片環圈能有效減緩橋墩周圍侵蝕，且選用三角形的葉片時，其效果較佳，安置環圈時，排成頂角面對水流的三角形，成果較佳，其成效也較消波塊好，推測可能可以產生分流的效果；另外三角形排列的夾角，應與橋墩之間存在特定比例關係，而非越大越好或越小越好，以結果來看，60度夾角最佳。

貳、研究目的

- 一、設計模擬實驗渠道。
 - (一) 三角形的柔性葉片。
 - (二) 鐮刀形的柔性葉片。
 - (三) 圓形的柔性葉片。
- 二、探討不同形狀的柔性葉片減少河道侵蝕的功效。
 - (一) 三角形的柔性葉片。
 - (二) 鐮刀形的柔性葉片。
 - (三) 圓形的柔性葉片。
- 三、探討不同排列的柔性葉片環圈減少河道侵蝕的功效。
 - (一) 正三角形（頂角朝向水流來向）。
 - (二) 倒三角形（對邊朝向水流來向）。
 - (三) 橫列（與河川流向垂直）。
- 四、探討三角形擺法在不同頂角下的柔性葉片環圈減少河道侵蝕的功效。
 - (一) 鈍角三角形（頂角為 135° ）。
 - (二) 直角三角形（頂角為 90° ）。
 - (三) 正三角形（頂角為 60° ）。
 - (四) 銳角三角形（頂角為 45° ）。
- 五、探討柔性葉片環圈和消波塊減少河道侵蝕的功效。
 - (一) 排列為三角形（頂角朝向水流來向）頂角 60° 的柔性葉片環圈。
 - (二) 排列為三角形（頂角朝向水流來向）頂角 60° 消波塊。

參、研究架構

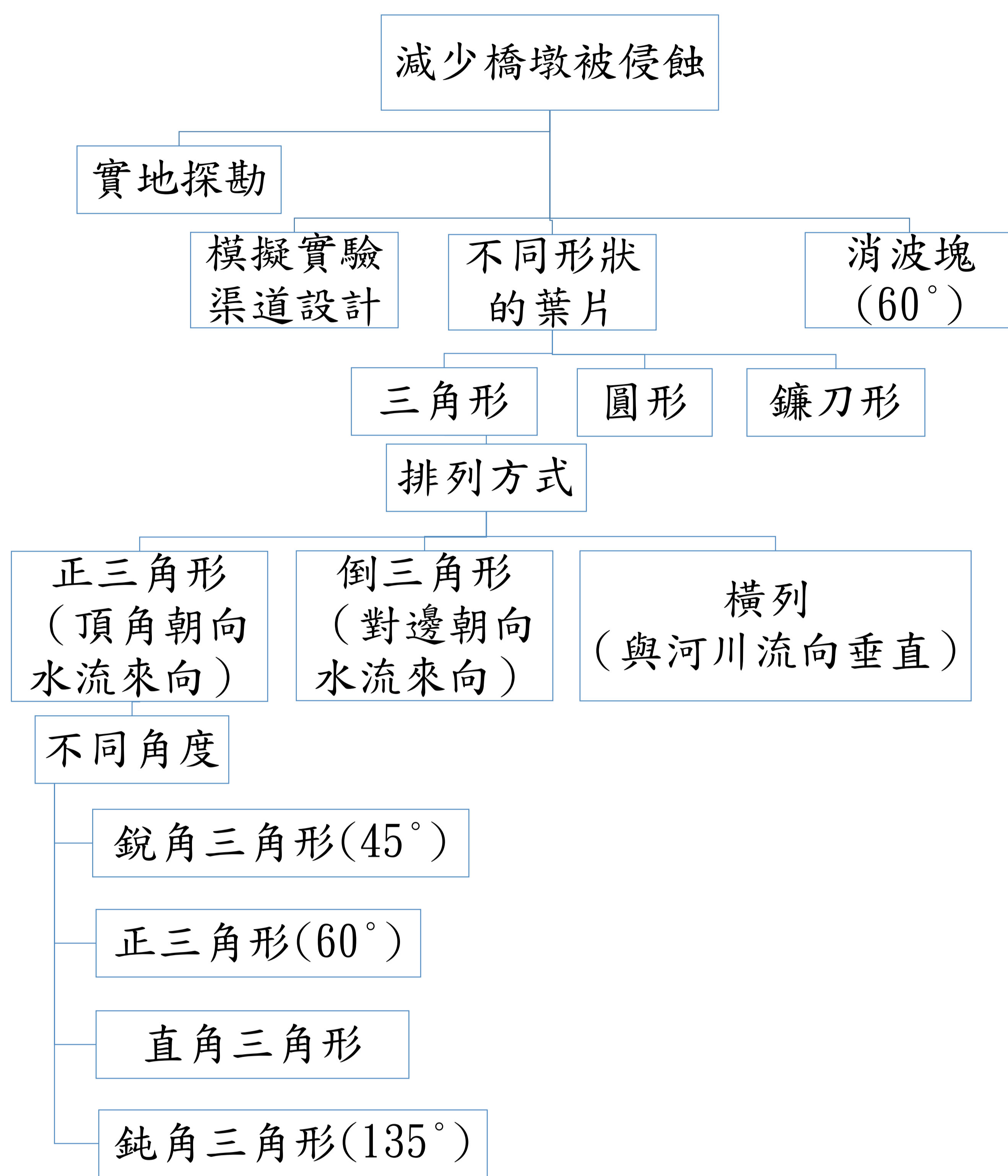

肆、設備及器材

一、水道整體配置

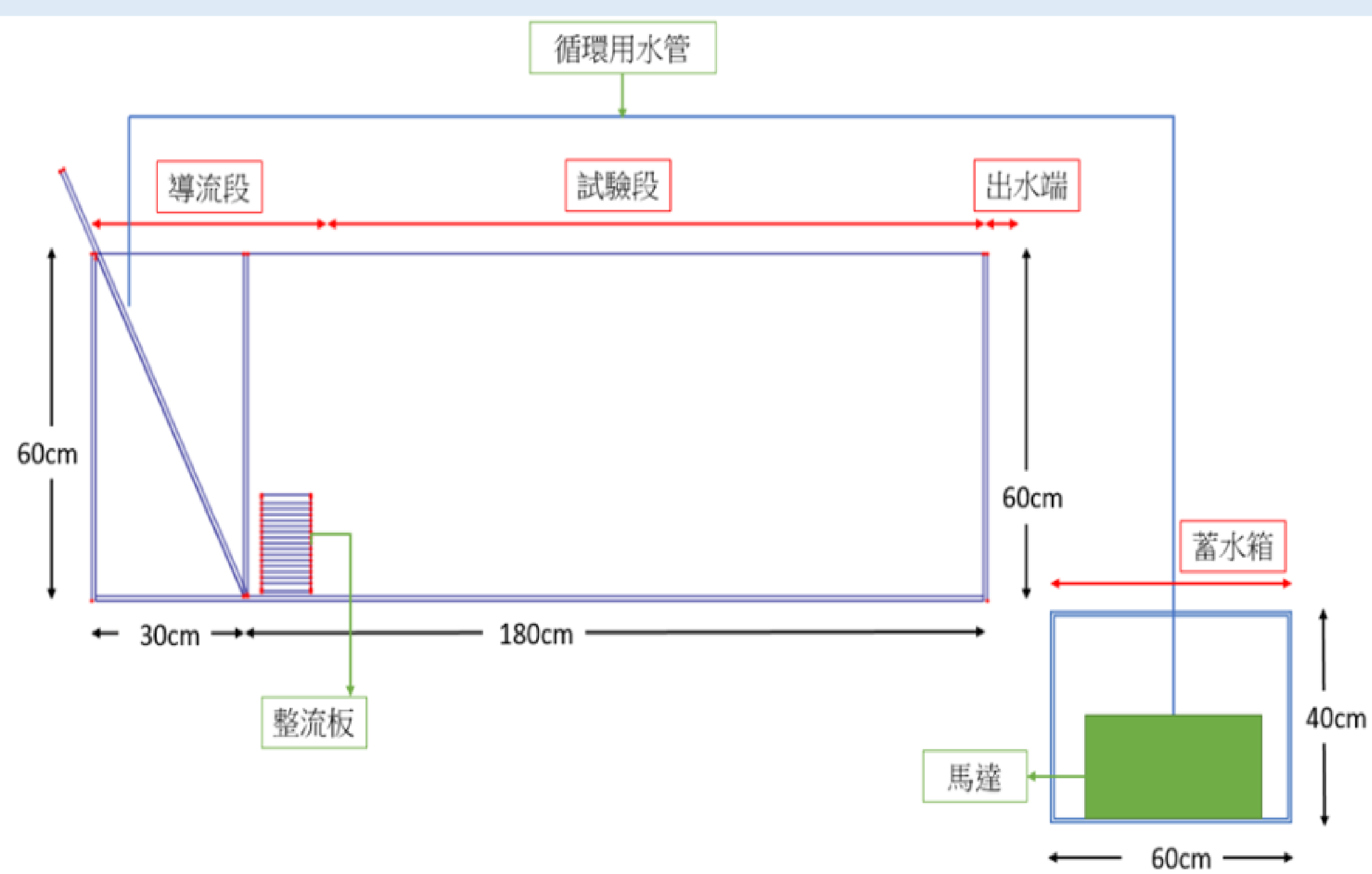

- (1) 前段：為導流段，放置導流板使水流穩定流出。
- (2) 中段：為試驗端，佈置泥砂，下方用珍珠板墊高使水能完全流出。

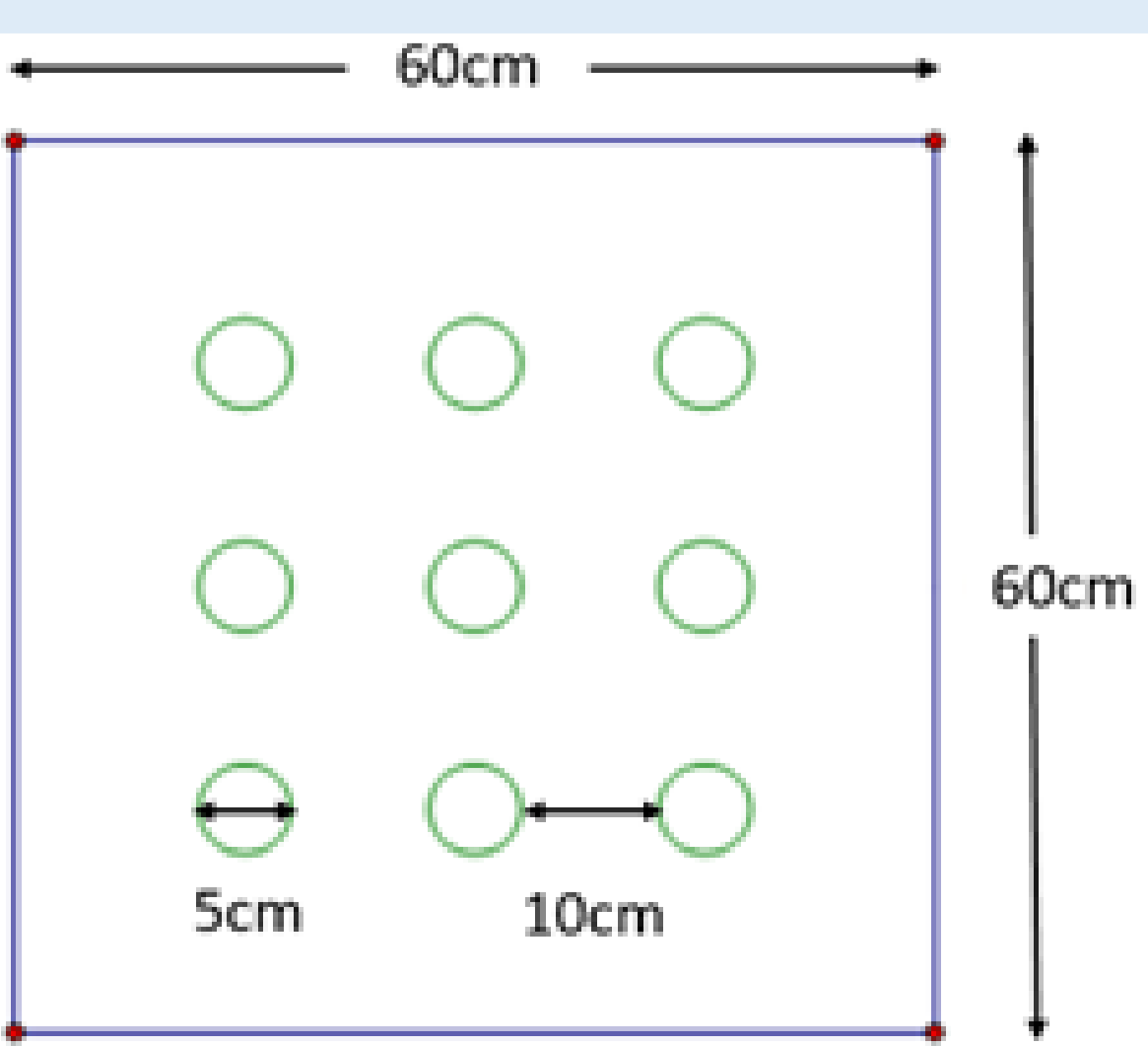

- (3) 後段：為出水端，水流自出水孔流出，進入蓄水箱後，再固定使用兩個抽水馬達作為固定流速，把水抽回導流段，達成循環的水流系統。

二、金屬葉片

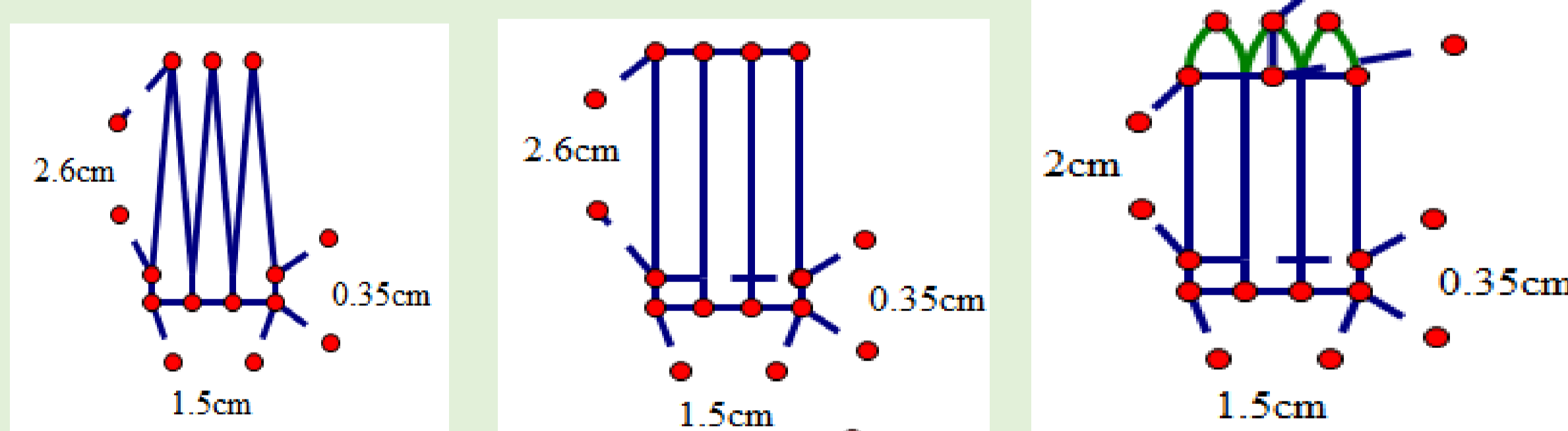

三角形葉片

鐮刀形葉片

圓形葉片

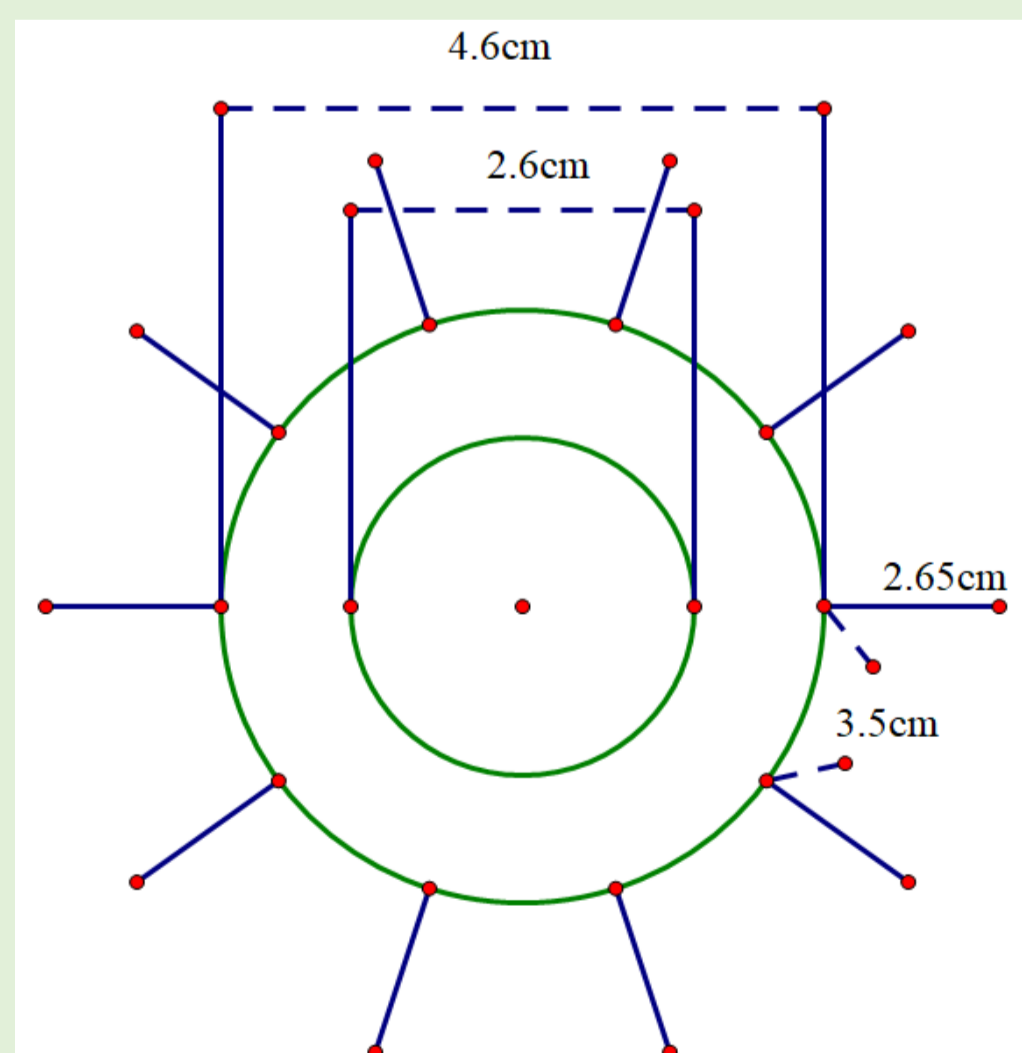

輪胎尺吋

樂高橡膠輪胎和我們設計的橋墩比例，與真實的碧潭大橋與輪胎一致。

三、珍珠板架

能在使用雷射測距儀時，將其放上孔洞上，隨之移動，固定每次觀察的位置。



伍、研究過程與方法

一、實驗配置

(一)探勘

1. 新店溪碧潭大橋，並向新北市第十河川局詢問橋墩尺吋。
2. 新店溪碧潭大橋下方的消波塊。



(二)泥沙來源：本實驗設計參照新店溪碧潭流域段，為確保粒徑大小與碧潭一致，所以本實驗使用之土壤底質來自於碧潭河岸。

(三)泥沙粒徑分析：隨機抽取樣本泥沙中50粒泥沙，並用dino-lite手持式顯微鏡觀測，再以image J軟體分析粒徑大小，平均粒徑大小為0.26mm。

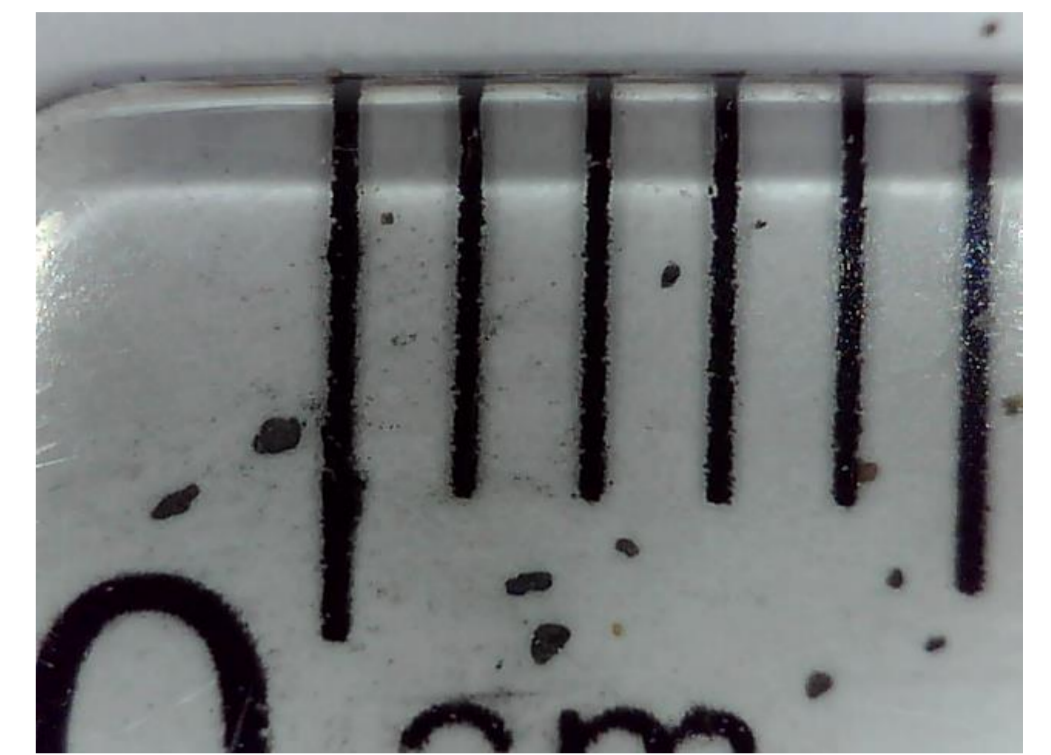

(四)實驗操作程序



二、對照組試驗：僅放置橋墩，前後無任何保護工。

三、探討不同形狀的柔性葉片減少河道侵蝕的功効



三角形葉片 (頂角60度)

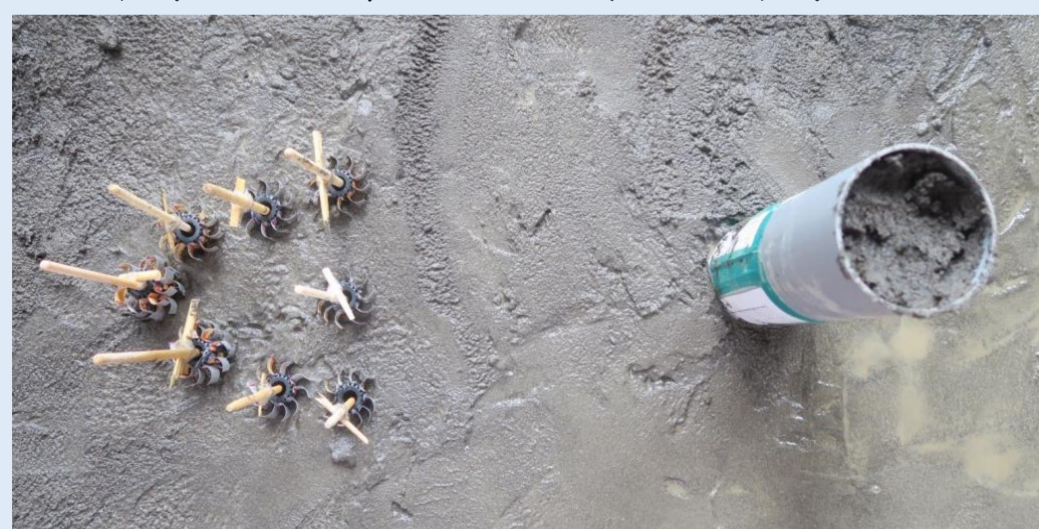

鐮刀形葉片 (頂角60度)

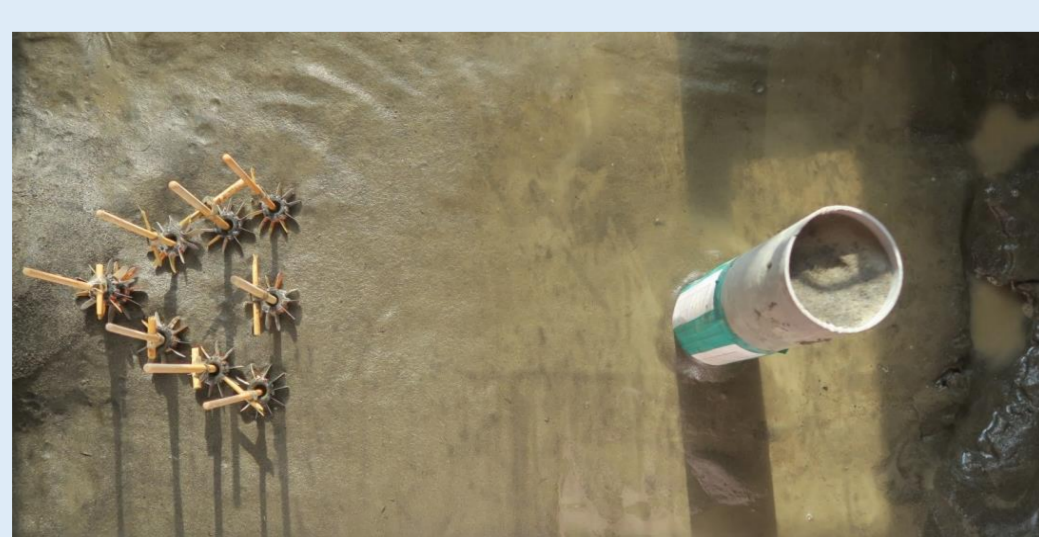

圓形葉片 (頂角60度)

四、探討不同排列方式的柔性葉片環圈減少河道侵蝕的功効



正三角形 (頂角朝向水流來向)

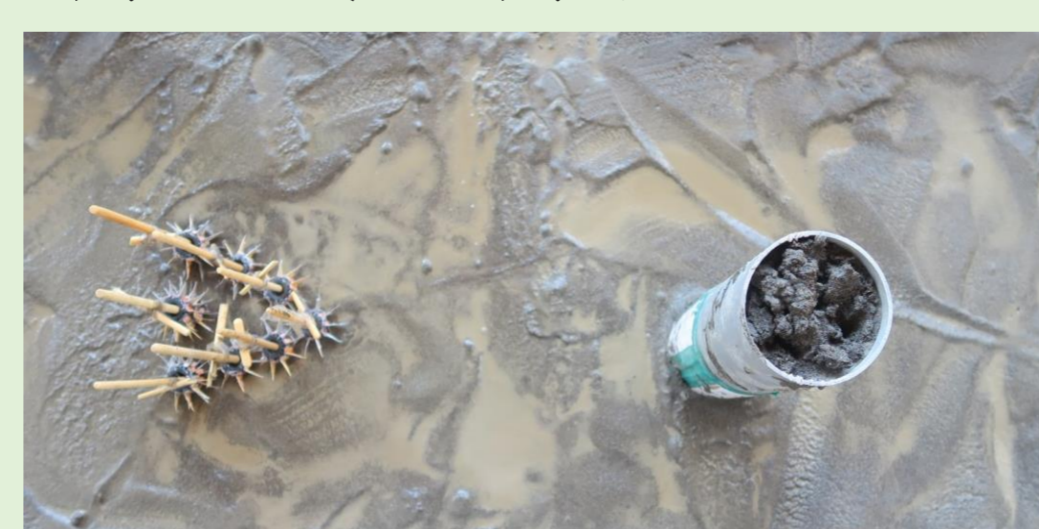

倒三角形 (對邊朝向水流來向)



橫列 (與河川流向垂直)

五、探討不同頂角的三角形柔性葉片環圈減少河道侵蝕的功効



頂角45度



頂角90度



頂角135度

六、探討消波塊減少河道侵蝕的功効



將12個消波塊以正三角形排列



消波塊尺寸：
高5cm*底6cm

陸、研究結果及討論

對照組地形圖

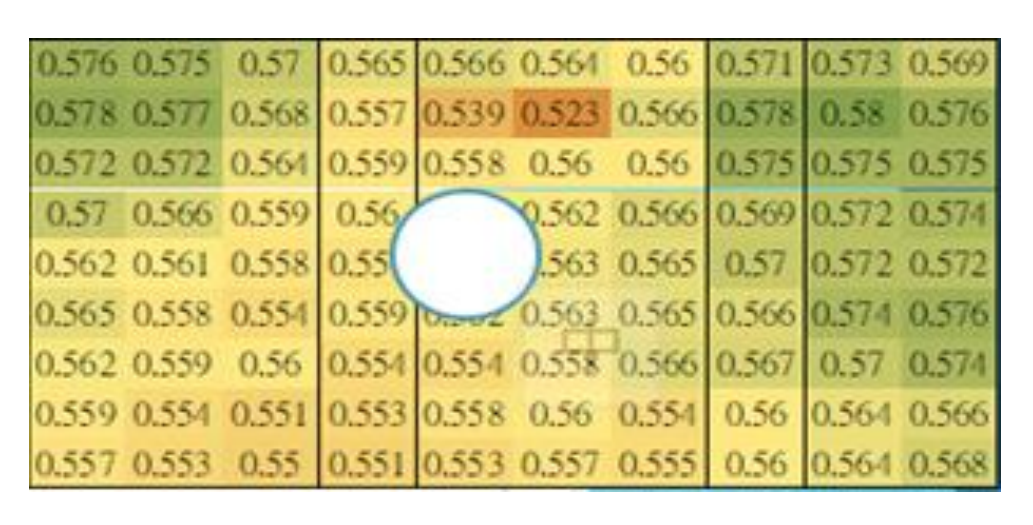

一、探討不同形狀的柔性葉片減少河道侵蝕的功効

(一)當葉片是三角形時，最能使水流速度下降，也是最能使橋墩前方不再產生侵蝕的組別，在地形圖中，可看到不論在橋墩前方或後方，皆能出現堆積，證明能有效抵擋水流沖蝕。

(二)推估可能是因三角形葉片相較圓形及鐮刀形葉片，較能用尖刺使水流流速減慢，讓水流受到擾亂，變為多道流速較慢且方向不同的水流，這也會導致其相互摩擦、干擾，致使流至橋墩後方時，因能量不足而無法帶走泥砂，進而沉澱下來；圓形葉片可能因其形狀，使水流被分散的力道較小。

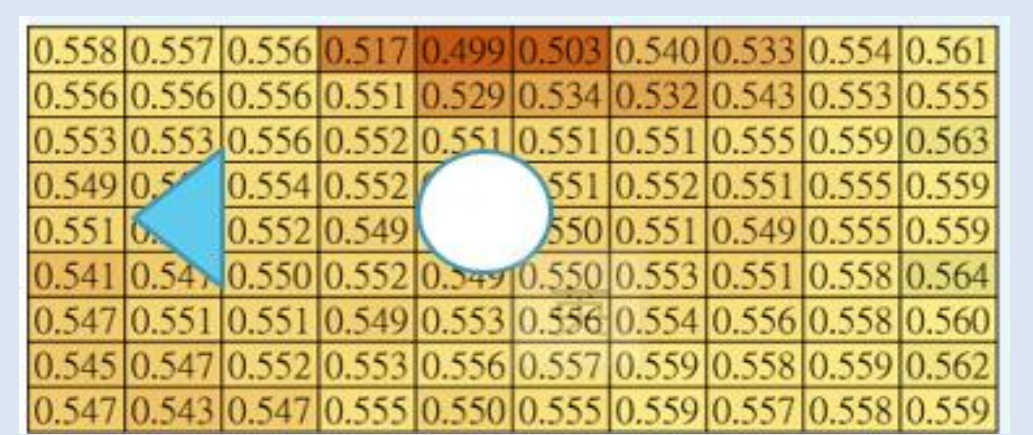
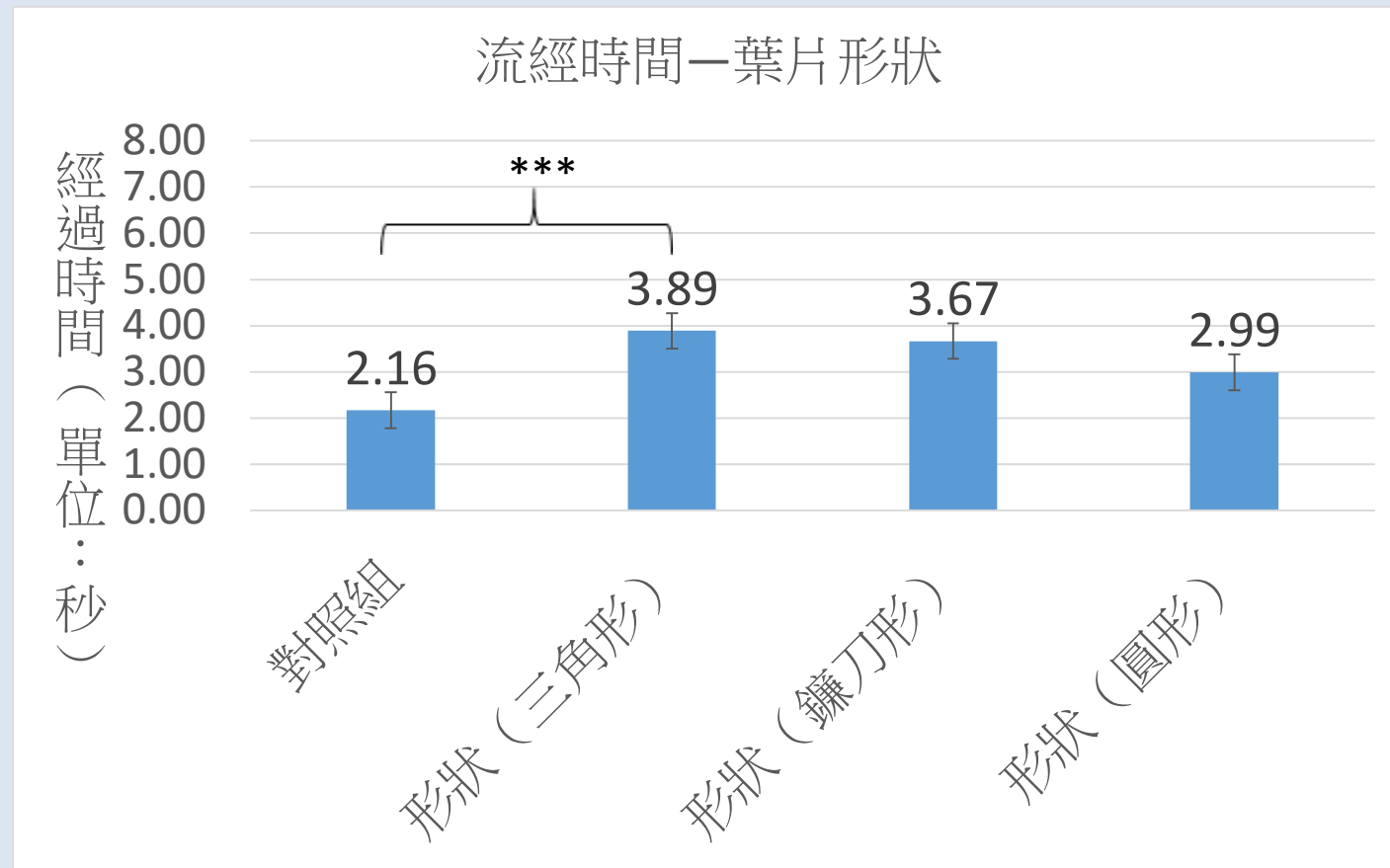
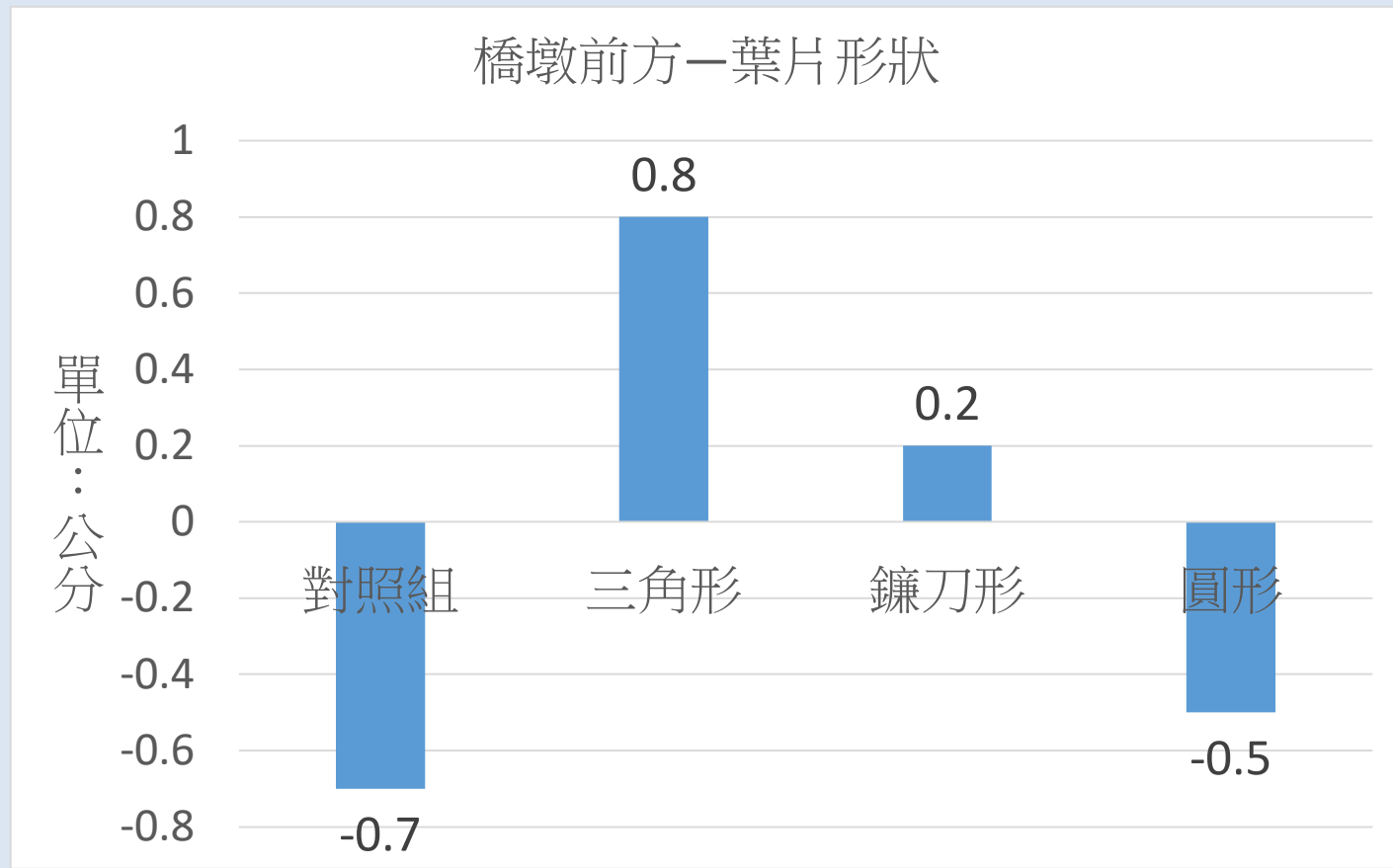

三角形葉片地形圖

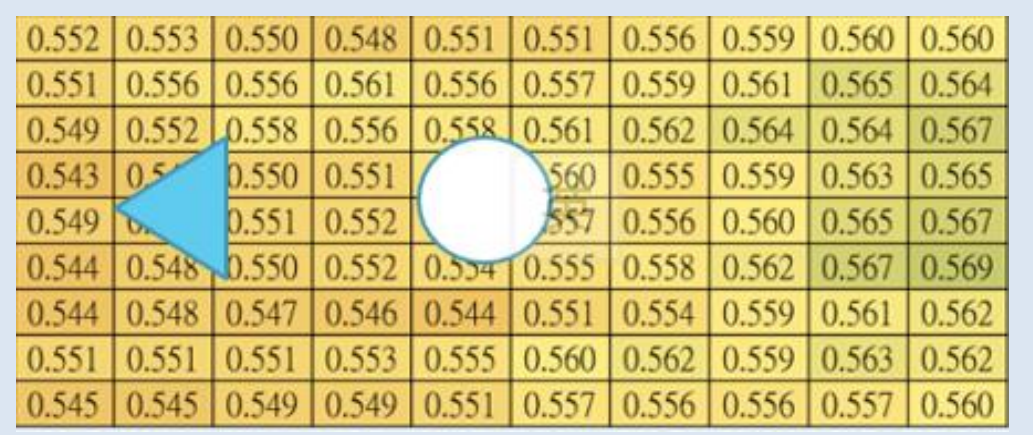

鐮刀形葉片地形圖



圓形葉片地形圖

二、探討不同排列方式的柔性葉片環圈減少河道侵蝕的功効

(一)正三角形的排列方式能協助水流進行導流，使其效果最佳，如同常見的沙洲形狀。

(二)倒三角形的排列方式可能會將水流更為集中在橋墩附近，造成橋墩附近水流碰撞變多，進而導致更多渦流產生，進而侵蝕橋墩。

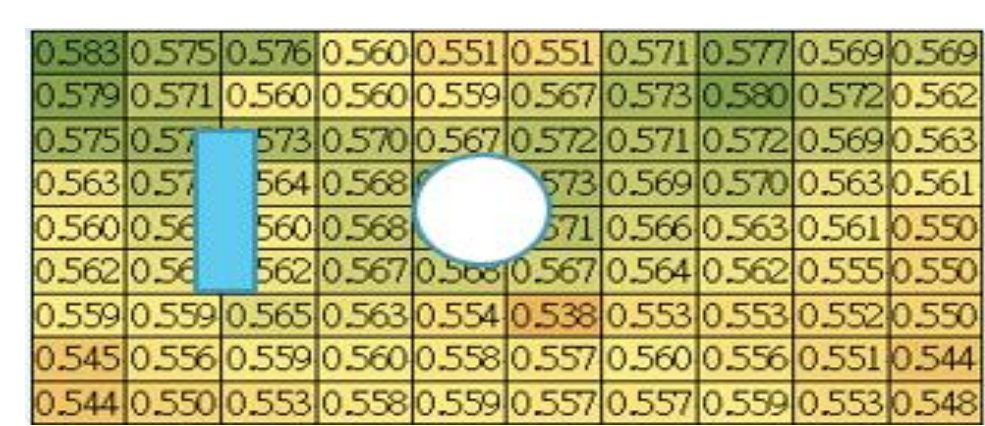
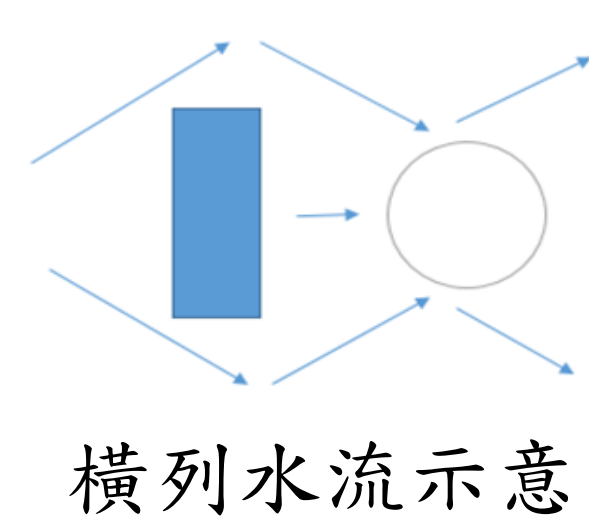

橫列 (與河川流向垂直)

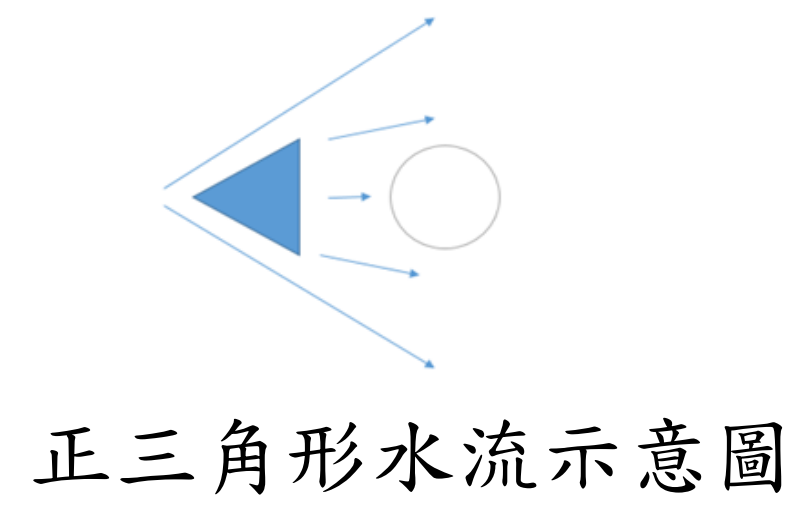
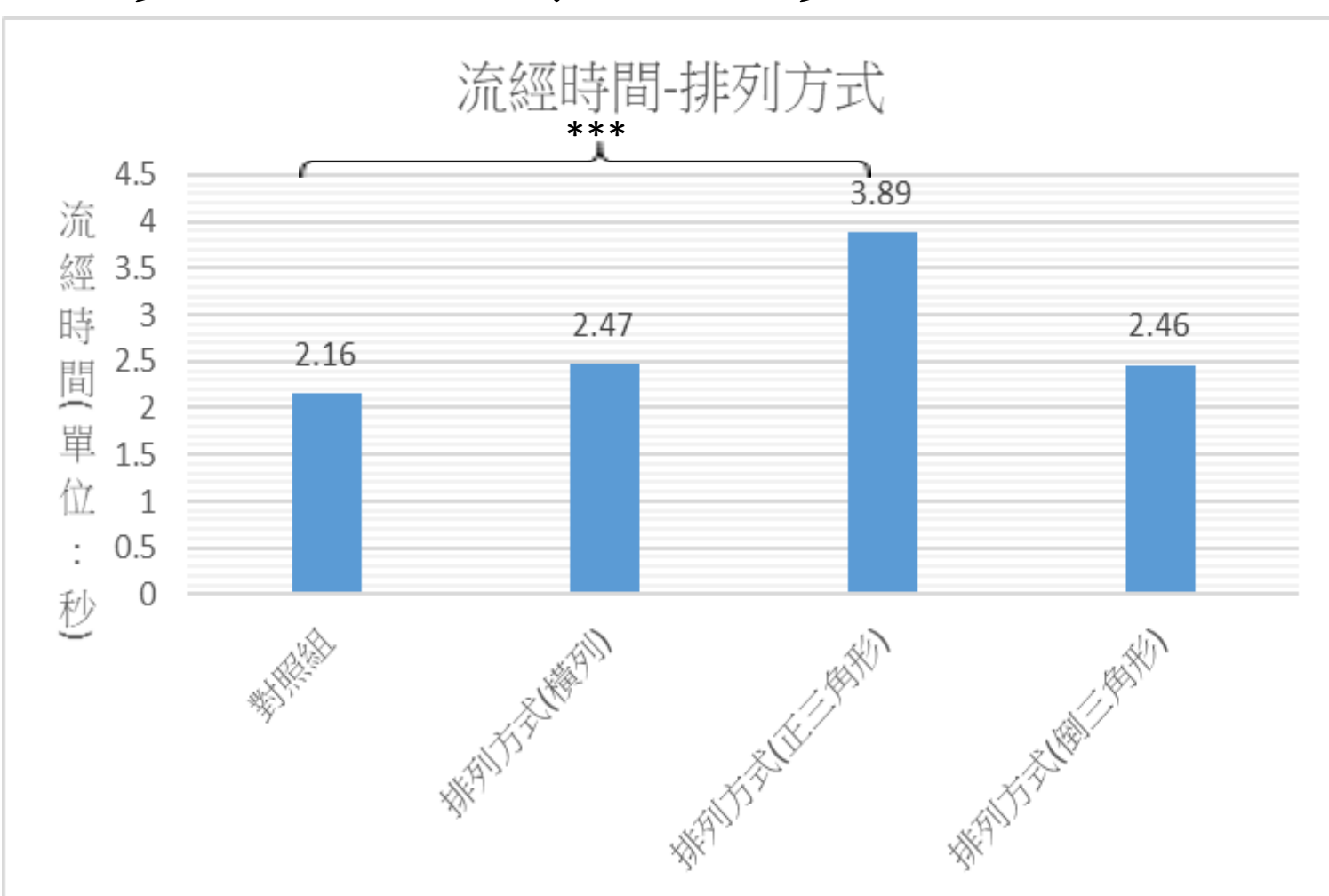

正三角形 (頂角朝向水流來向)

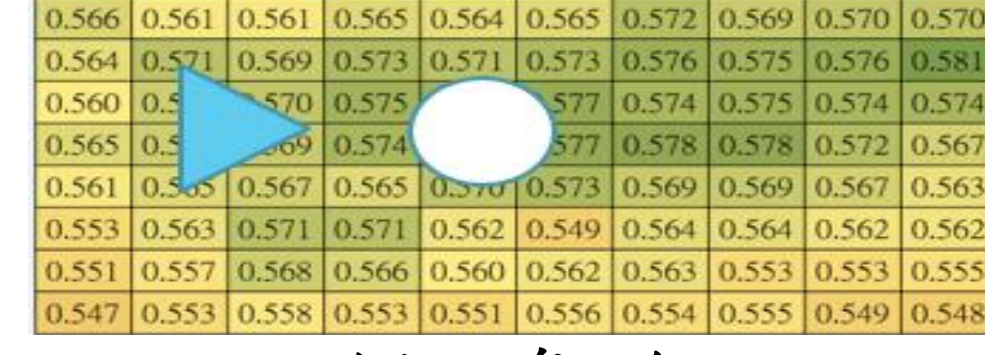
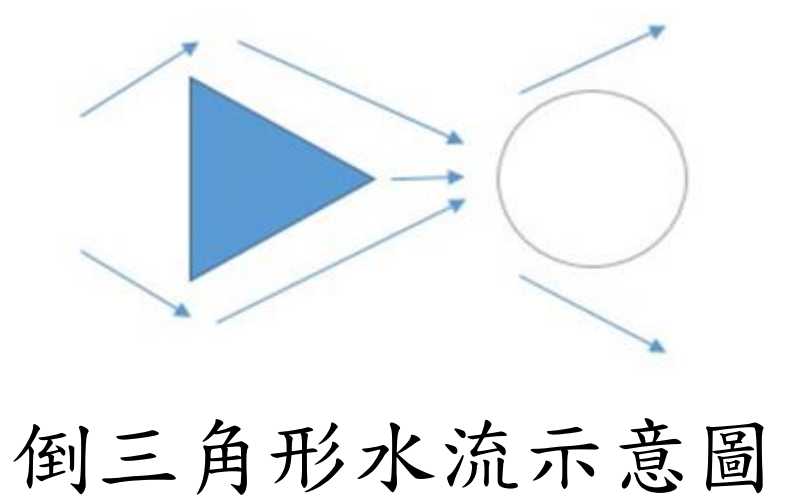

倒三角形 (對邊朝向水流來向)

三、探討不同頂角的柔性葉片環圈減少河道侵蝕的功効

(一)以我們的三角形的葉片和排列密度，面對水流呈現六十度角時，效果會最好。

(二)雖然並沒有做出每一個可能的角度，然而我們可以看到兩項趨勢：

1. 若是夾角太小，雖然形成分流，但是兩側的角度不夠，水流到橋墩時減速和分流的效果並沒有那麼樣的好。
2. 若是夾角太大，分流的效果普遍不明顯，那麼就近似於前一項實驗的橫列型裝置了。

(三)葉片的排列方式必須呈現某個角度，而這角度可能和橋墩的大小以及安置區以及橋墩的距離有關，可以視情況做調整。

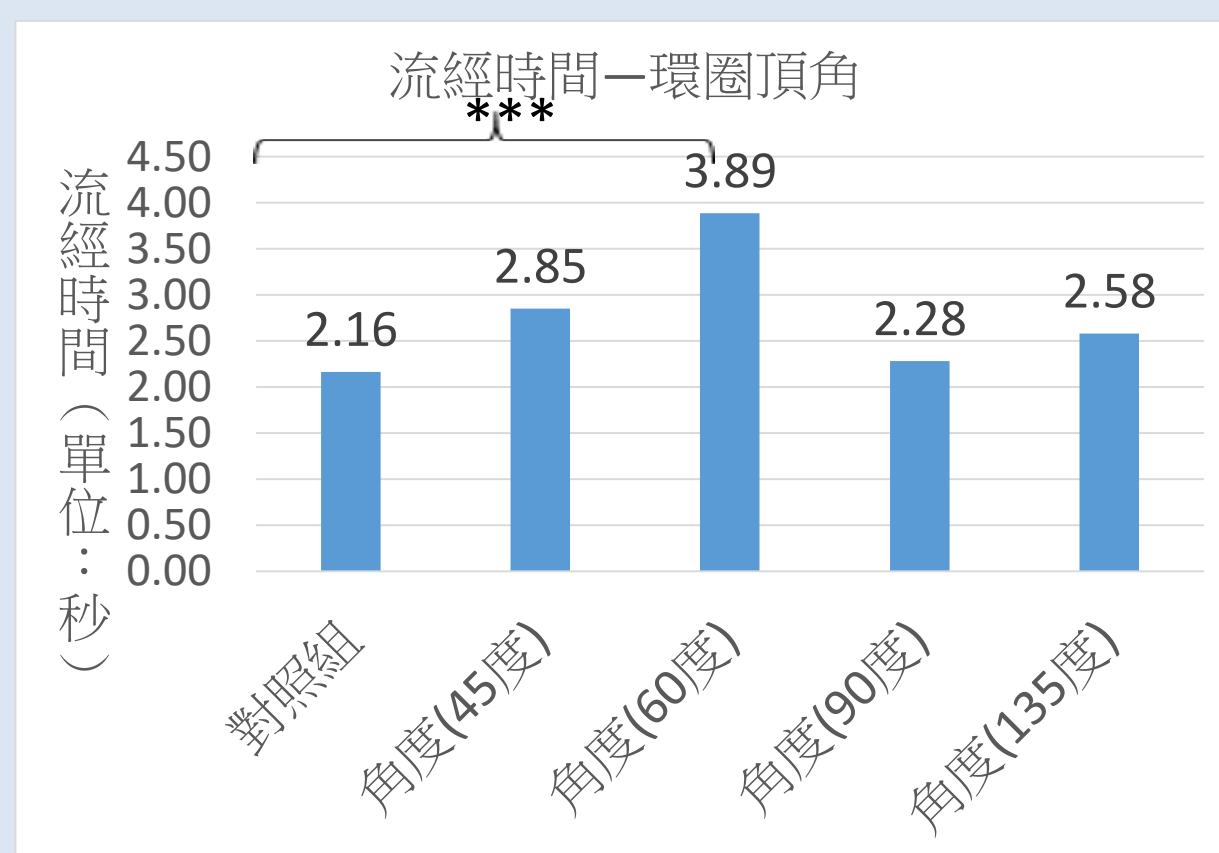
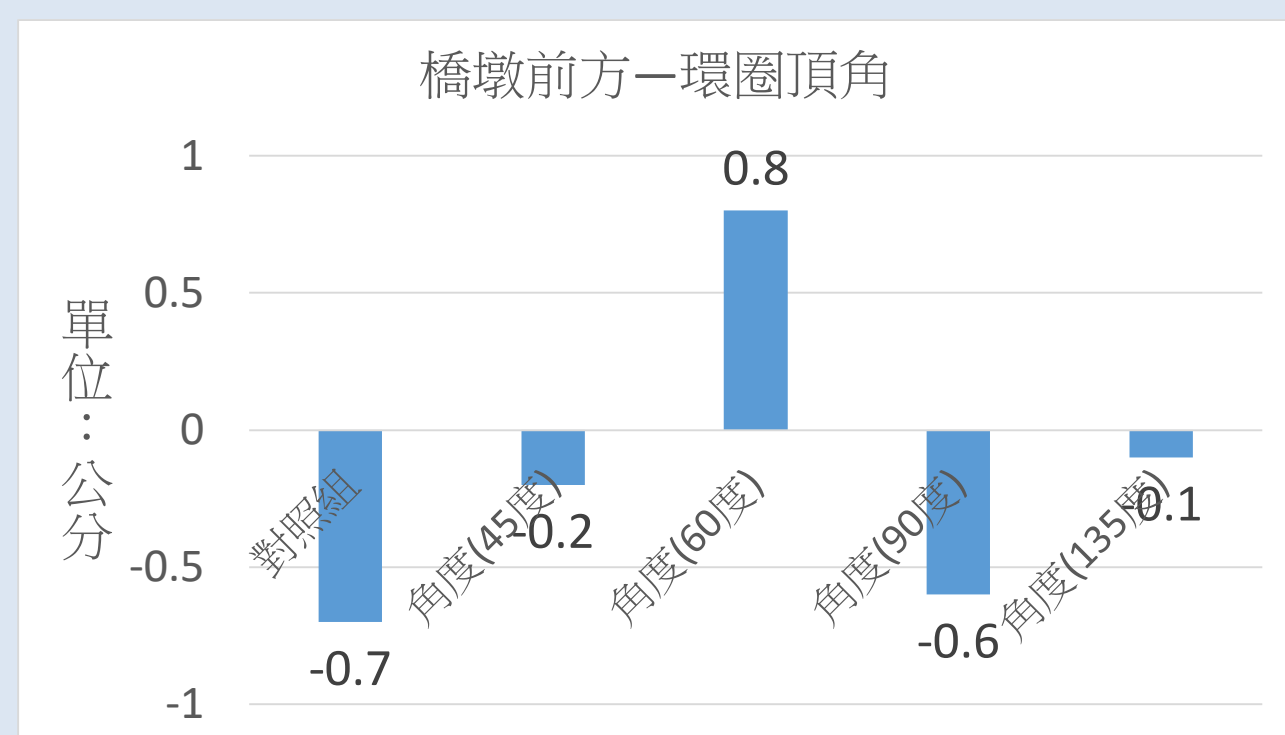

45度

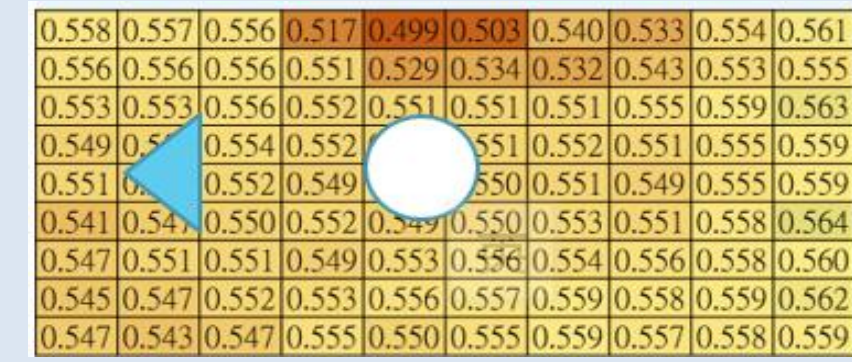

60度



90度



135度

四、比較消波塊與柔性葉片環圈減少河道侵蝕的功効

比較皆為頂角為60度的柔性葉片環圈及消波塊，發現消波塊防止橋墩侵蝕的效果比柔性葉片環圈差，因此推測在一定程度上，柔性葉片環圈能替代消波塊。

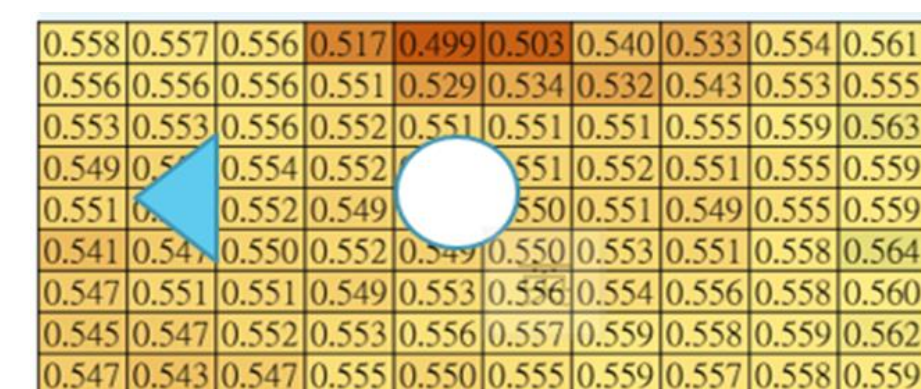
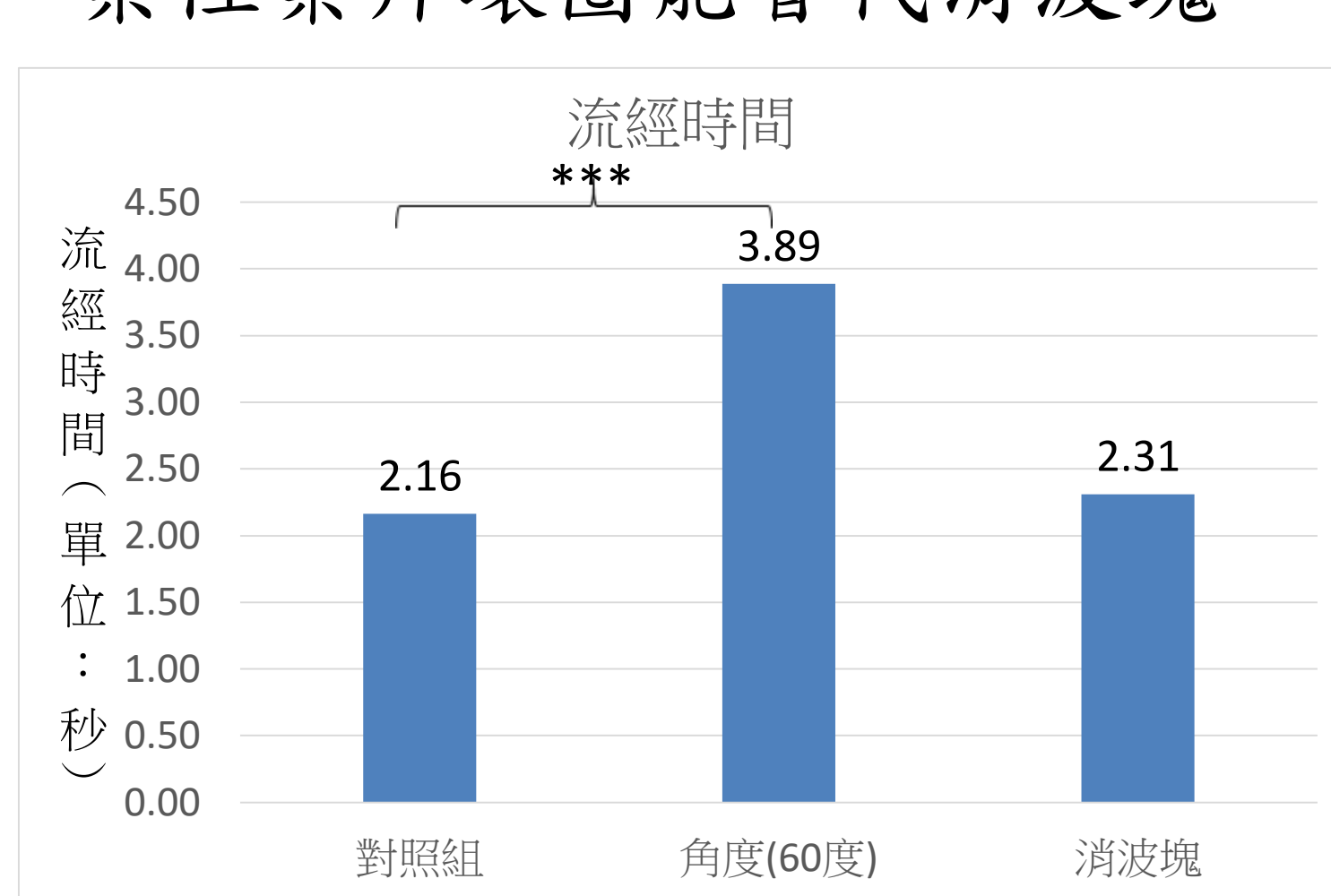
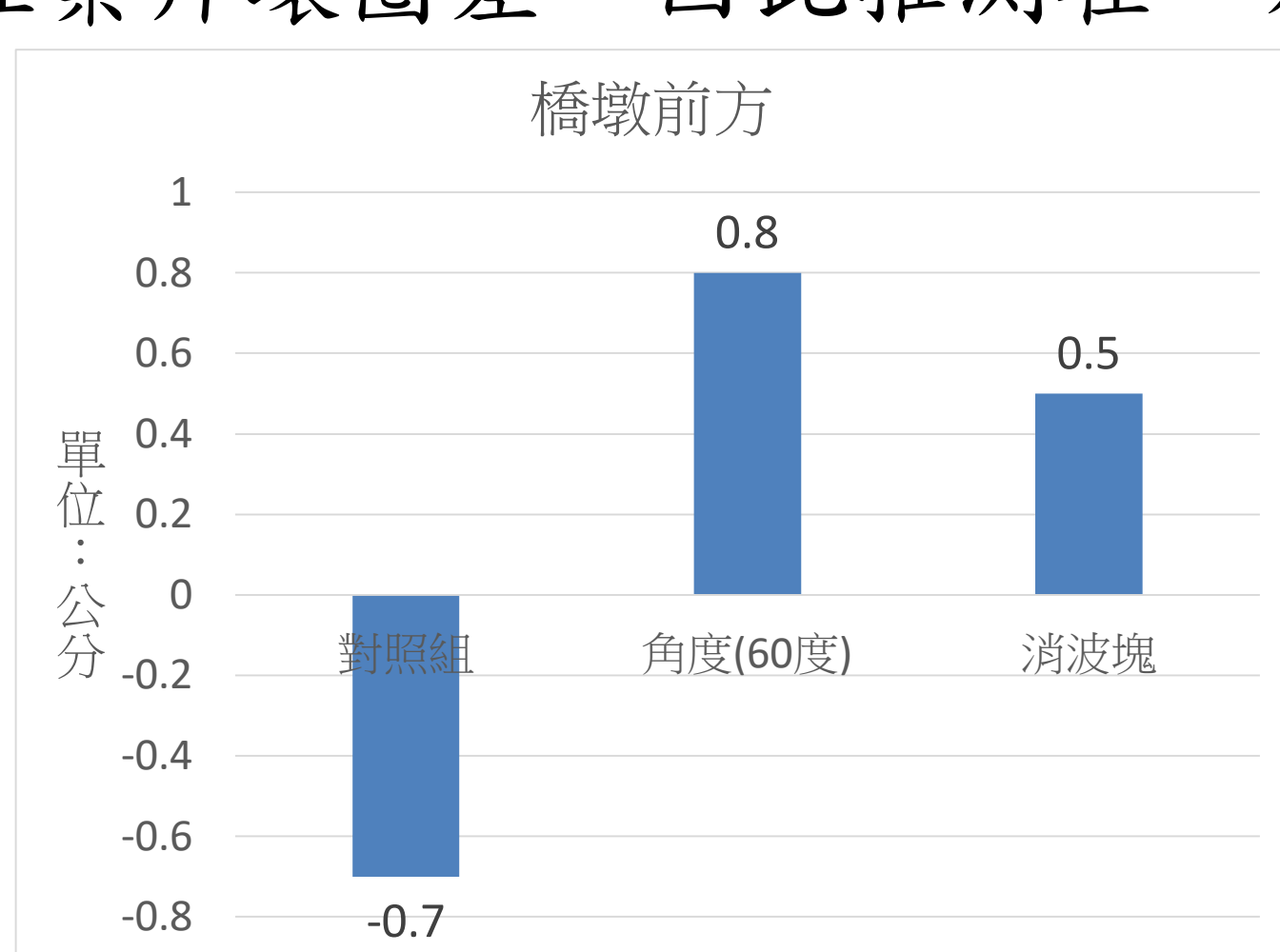

排列方式為頂角60度正三角形的柔性葉片環圈



排列方式為頂角60度正三角形的消波塊

柒、結論

- 一. 柔性葉片能有效的減緩橋墩周圍侵蝕。
- 二. 葉片造型選用三角形時，其效果較佳。
- 三. 安置環圈時，將其排成頂角面對水流的三角形，成果較佳，可能可以產生分流的效果。
- 四. 三角形排列的夾角，應與橋墩之間存在特定比例關係，而非單純越大越好或越小越好。
- 五. 推測在一定程度上，柔性葉片環圈能替代消波塊。

捌、參考文獻

- 一. 彭大雄、徐郁超及詹錢登 (2010)。柔性葉片環圈堆保護工應用於橋墩沖刷現地試驗之研究。土木水利，第37卷 第2期，第63~75頁。
- 二. 程仕帆(2003)。套環保護工法對減少橋墩局部沖刷之研究。國立中央大學土木工程研究所碩士論文。